

RollSeal®

Automated Systems

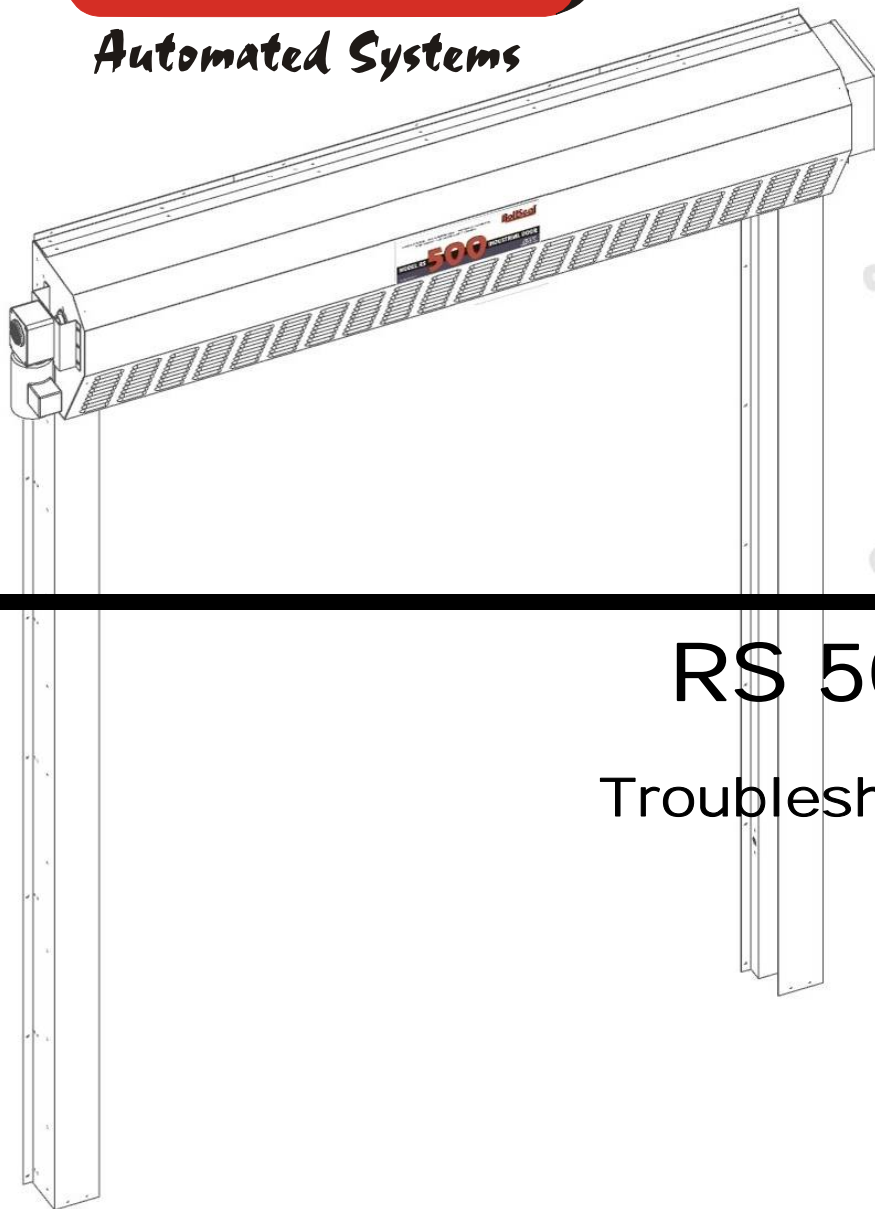

RS 500 DOOR Troubleshooting Guide

RollSeal
PO Box 140
1751 County Road 68
Bremen, Alabama 35033

Table of Contents

1.	INTRODUCTION	7
1.1	How the SC-325 Communicates with the RollSeal RS-500 Door.....	8
1.2	SC-325 V1 Controller Layout.....	9
1.3	SC-325 V2 Controller Layout.....	10
1.4	Obstructed LED	11
1.5	RS-500 Door.....	11
2.	TROUBLESHOOTING FLOWCHART	12
2.1	Article 1 - Unknown Position Indication.....	14
2.2	Article 2 - Error Codes	15
2.3	Article 3 - Jog Mode.....	20
2.4	Article 4 - SC-325 Drive Diagnostic LEDs.....	21
2.5	Article 5 - Switch Testing	22
2.6	Article 6 - Adjusting the HOME, Safety, and Lead Edge Switches	26
2.7	Article 7 - Test Brake Relay	30
3.	RollSeal Automatic Door Wiring Diagram.....	34
4.	RollSeal Smart Controller Wiring Diagram.....	35

Please Retain This Manual for Future Reference

Warnings (Avertissements)

Warning!

Disconnect All Power Sources Before Installing This Equipment. Failure To Disconnect Power Source Can Result In Property Damage, Serious Injury Or Death!

Warning!

Dangerous Rotating Machinery!
Keep Hands, Clothing, Etc. Clear When Operating!
Do Not Operate Without All Guards And Covers In Place!

Warning!

All Wiring Should Be In Accordance with National Electrical Codes Or Other Local Codes.

Warning!

The Installer Is Responsible For Complying With All Relevant Regulations, Such As National Wiring Regulations And Accident Prevention Regulations. Particular Attention Must Be Given To The Cross-sectional Areas Of Conductors, The Selection Of Fuses Or Other Protection, And Protective Earth/Ground Connections!

Warning!

The Voltages In The Power Cables And Certain Parts Of The Drive Can Result In Death. Whenever The Drive Has Been Used It Must Be Isolated And Disconnected For 5 Minutes Before Any Work Commences.

Danger!

Only Qualified Electrical Personnel Familiar With The Construction And Operation Of This Equipment And The Hazards Involved Should Install, Adjust, And/Or Service This Equipment. Read And Understand This Manual In Its Entirety Before Proceeding. Failure To Observe This Precaution Could Result In Severe Bodily Injury Or Death!

IMPORTANT INSTALLATION INSTRUCTIONS

WARNING!

To reduce the risk of severe injury or death:

1. READ AND FOLLOW ALL INSTALLATION INSTRUCTIONS.
2. Do not connect the door operator to the source of power until instructed to do so.
3. Locate the control station: (a) within sight of the door, (b) at a minimum height of 5 feet so small children cannot reach it, and (c) away from all moving parts of the door.
4. For products having a manual release, instruct the end user on the operation of the manual release.

IMPORTANT SAFETY INSTRUCTIONS

WARNING!

To reduce the risk of severe injury or death:

1. READ AND FOLLOW ALL INSTRUCTIONS!
2. Never let children operate or play with door controls. Keep the remote control (where provided) away from children.
3. Personnel should keep away a door in motion and keep the moving door in sight until it is completely closed or opened. **NO ONE SHOULD CROSS THE PATH OF A MOVING DOOR.**
4. Test the door's safety features at least once a month. After adjusting either the speed or the limit of travel, retest the door operator's safety features. Failure to adjust the operator properly may cause severe injury or death.
5. For products having a manual release, if possible, use the manual release only when the door is closed. Use caution when using this release when the door is open.
6. **KEEP DOORS PROPERLY OPERATING AND BALANCED.** See Door Manufacturer's Owner's Manual. An improperly operating or balanced door can cause severe injury or death. Have trained door systems technician make repairs to cables, spring assemblies, and other hardware.
7. **SAVE THESE INSTRUCTIONS.**

French Translated Warnings

Avertissement!

Disjoindre fournissent de l'énergie tout les sources avant qu'installer cet équipement. F|ailure| à disjoindre la source de pouvoir peut résulter dans dommage de propriété, blessure sérieuse ou mort !

Avertissement !

Mécanisme tournant dangereux !
Garder les mains, vêtissant, etcC|lear| quand fonctionner !
Ne fonctionnez pas sans toutes gardes et couvertures dans lieu !

Avertissement !

Tout montage sur fil de fer doit être selon codes électriques nationaux ou autres indicatifs régionaux.

Avertissement !

L'Installer est responsable pour conformer avec tout règlement pertinent, telles que règlement et règlement de prévention d'accident de montage sur fil de fer nationaux. Pl'attention articulaire doit être donnée pour les aires sectionnelles transversales de conducteurs, le choix d'elles fusées ou autre protection, et terre / prises de terre protecteur !

Avertissement !

Les tensions dans le pouvoir câblent et certains parties de la promenade en voiture peuvent résulter dans la mort. Wle |henever| la promenade en voiture a été utilisé il doit être isolé et détaché pendant 5 procès avant que tout travail commence.

Danger !

Seulement familier électrique de personnel qualifié avec la construction et opération de cet équipement et les hasards ont enveloppé devoir installer, arranger, et/ou - la révision cet équipement. R|ead| et comprendre ce manuel en entier avant que procéder. F|ailure| à observer cette précaution peut résulter dans dommage corporel sévère ou mort !

LES INSTRUCTIONS D'INSTALLATION IMPORTANTES

AVERTISSEMENT!

À réduire le risque de blessure sévère ou mort:

1. LU ET SUIVENT TOUTES INSTRUCTIONS D'INSTALLATION.
2. Ne liez pas l'opérateur de porte per la source de pouvoir jusqu'à instruit faire ainsi.
3. Localisez la station de commande: (a) en vue de la porte, (b) à un minimum la hauteur de 5 pieds ainsi petit enfants ne peuvent pas l'atteindre, et (c) loin de tous parties en mouvement de la porte.
4. Pour produits ayant un délivrance manuelle, instruire l'utilisateur final sur l'opération de la délivrance manuelle.

RÈGLEMENTS DE SÉCURITÉ IMPORTANTS

AVERTISSEMENT!

À réduire le risque de blessure sévère ou mort:

1. LU ET SUIVENT TOUTES INSTRUCTIONS!
2. Jamais laisser fonctionner enfants ou mouvoir vivement avec les autorités de porte. Gardez la télécommande (où a fourni) loin des enfants.
3. Le personnel devrait garder loin une porte dans mouvement et subsistance la porte en mouvement dans vue jusqu'à est complètement fermé ou avoir ouvert. **CES AUCUNS DOIVENT CROISER LE CHEMIN D'UNE PORTE EN MOUVEMENT.**
4. Éprouvez les traits de sécurité de la porte au moins une fois par mois. Après qu'arrangeant la vitesse ou la fin de course, retest les traits de sécurité de l'opérateur de porte. Manque à arranger l'opérateur correctement peut causer blessure sévère ou mort.
5. Pour produits ai manuel la délivrance, si possible, utiliser la délivrance manuelle seulement quand la porte est fermée. Précaution d'utilisation à utiliser cette délivrance quand la porte est ouverte.
6. **GARDER LES PORTES CORRECTEMENT QUI OPÈRE ET ÉQUILIBRÉ.** Voir la porte fabricant propriétaire manuel. Un improprement qui opère ou balancé porte peut causer blessure sévère ou mort. Formez les technicien de systèmes de porte faites les réparations per les câbles, réunions de source, et autre quincaillerie.
7. **SAUVEZ CES INSTRUCTIONS.**

1. INTRODUCTION

In trouble shooting this control look over this introduction to get familiar with the control and start with the flow chart provided. When starting with the flow chart it is assumed that the control has already been set up and the limits have been programmed in the control. Any programming information can be found in the 4801-5156 manual for the SC-325 control. Also the display in which the flow chart refers to is the **Display Indicator** on the front of the SC-325 control which can be seen on this page below.

CAUTION: Any electrical trouble shooting performed in this guide should be performed by a qualified electrician.

The RollSeal SC-325 is an intelligent controller manufactured specifically for the RollSeal RS-500 Automatic Door. The SC-325 will provide safe opening and closing of the door by using a number of internal safety devices plus those features provided in the components of the RS-500 door. The SC-325 can control the opening and closing speeds of the door, count the number of door operations, and provide status information for remote monitoring of the door position. In addition, the SC-325 can combine a number of auxiliary devices to improve the operability of the RS-500 door such as:

- (1) Infrared sensors to detect the presence of personnel or machinery requiring passage through the door.
- (2) Remote radio controlled inputs for operating the door.
- (3) Auxiliary lights or alarms that operate in conjunction with door opening or closing.

The SC-325 controller is very versatile and simple to operate. The controls are easily operated from the front panel.



1.1 **How the SC-325 Communicates with the RollSeal RS-500 Door.**

Inside the upper right housing of the RollSeal RS-500 door is an encoder that sends electrical pulses to the SC-325 when the door is moving and the controller is in the normal operating mode. (See Section *RollSeal 500 Door Wiring Diagram* of the 4801-5156 manual for wiring diagram of the encoder). The SC-325 refers to the position of the door in units of “Counts”, which is based upon the number of encoded pulses that the encoder sends to the controller.

NOTE: The term Position Units is used throughout this document and refers to the position of the door in units of Counts.

A Count of zero is assigned to the full open position where the Home switch operates, and the highest count is assigned to the full closed position. The maximum number of counts that the SC-325 will read will depend upon the particular installation. In general, a count is approximately equal to 1/8 inch of door movement. Several of the parameters of the SC-325 are displayed in units of Counts, such as the Actual Position, the Open and Closed Limit Positions and the Acceleration and Deceleration Ranges.

1.4 Obstructed LED

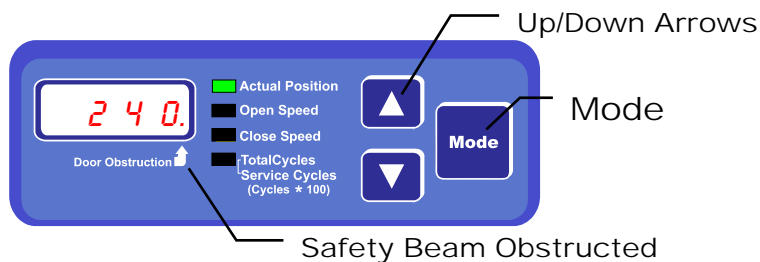

1.5 RS-500 Door

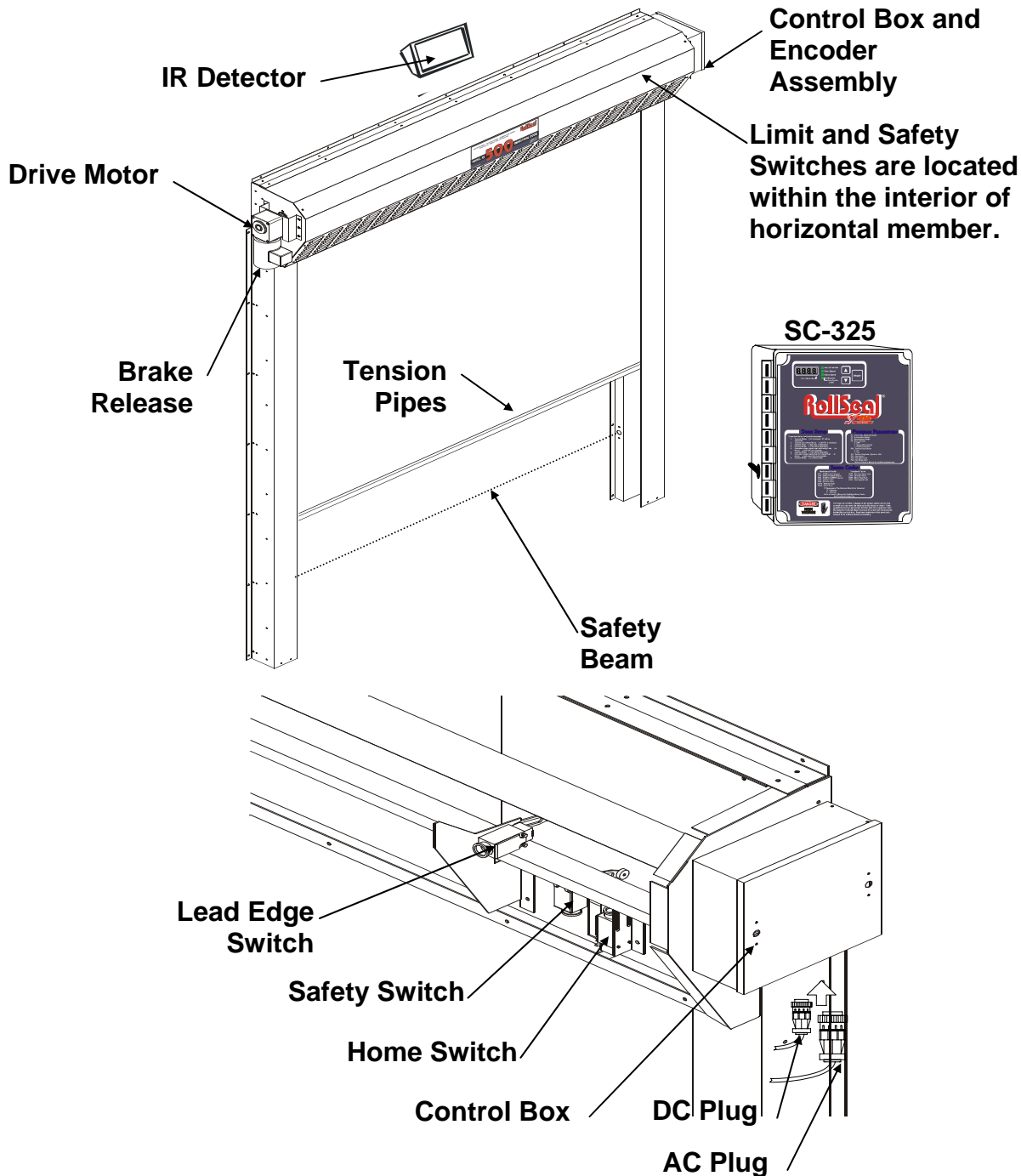

2. TROUBLESHOOTING FLOWCHART

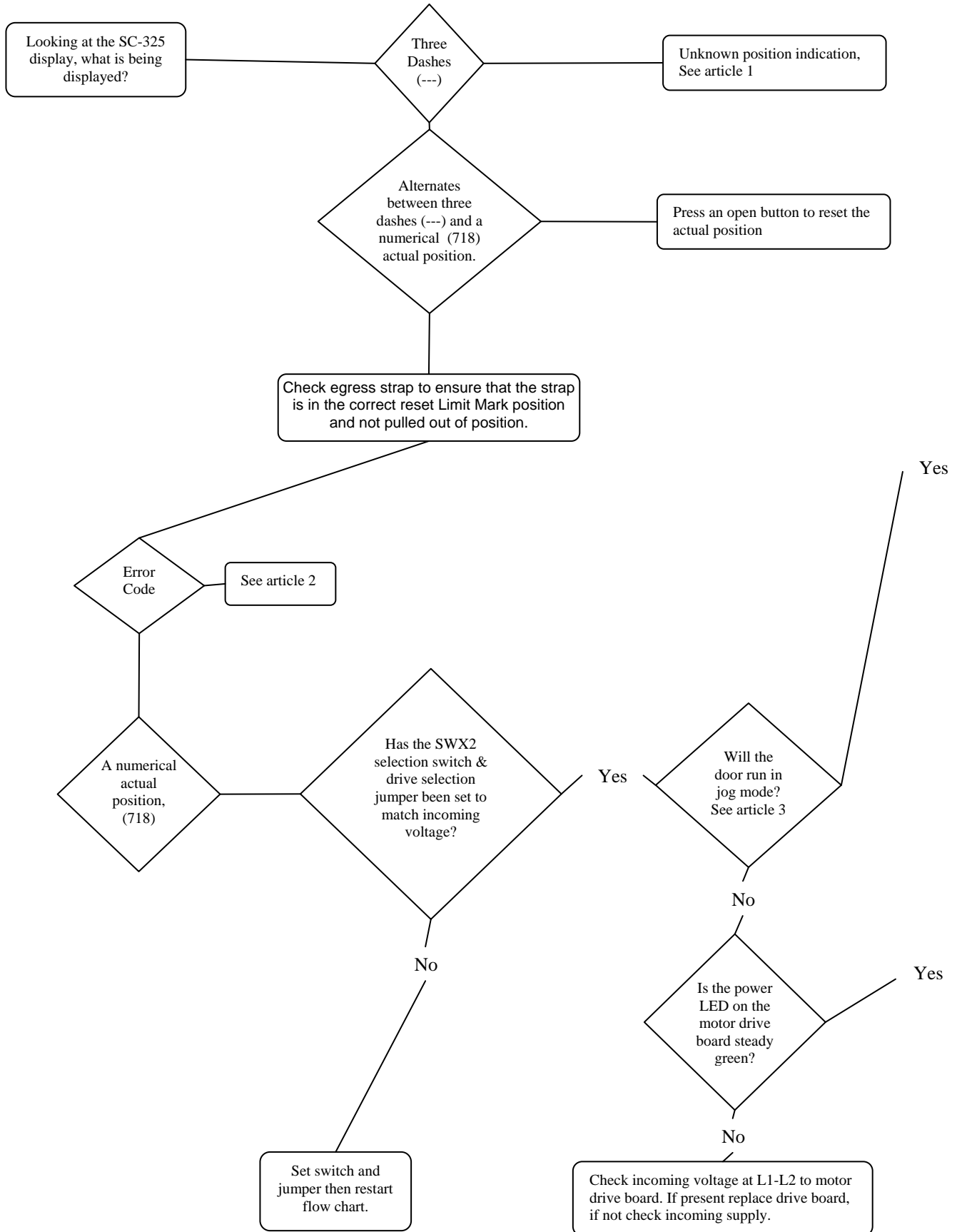

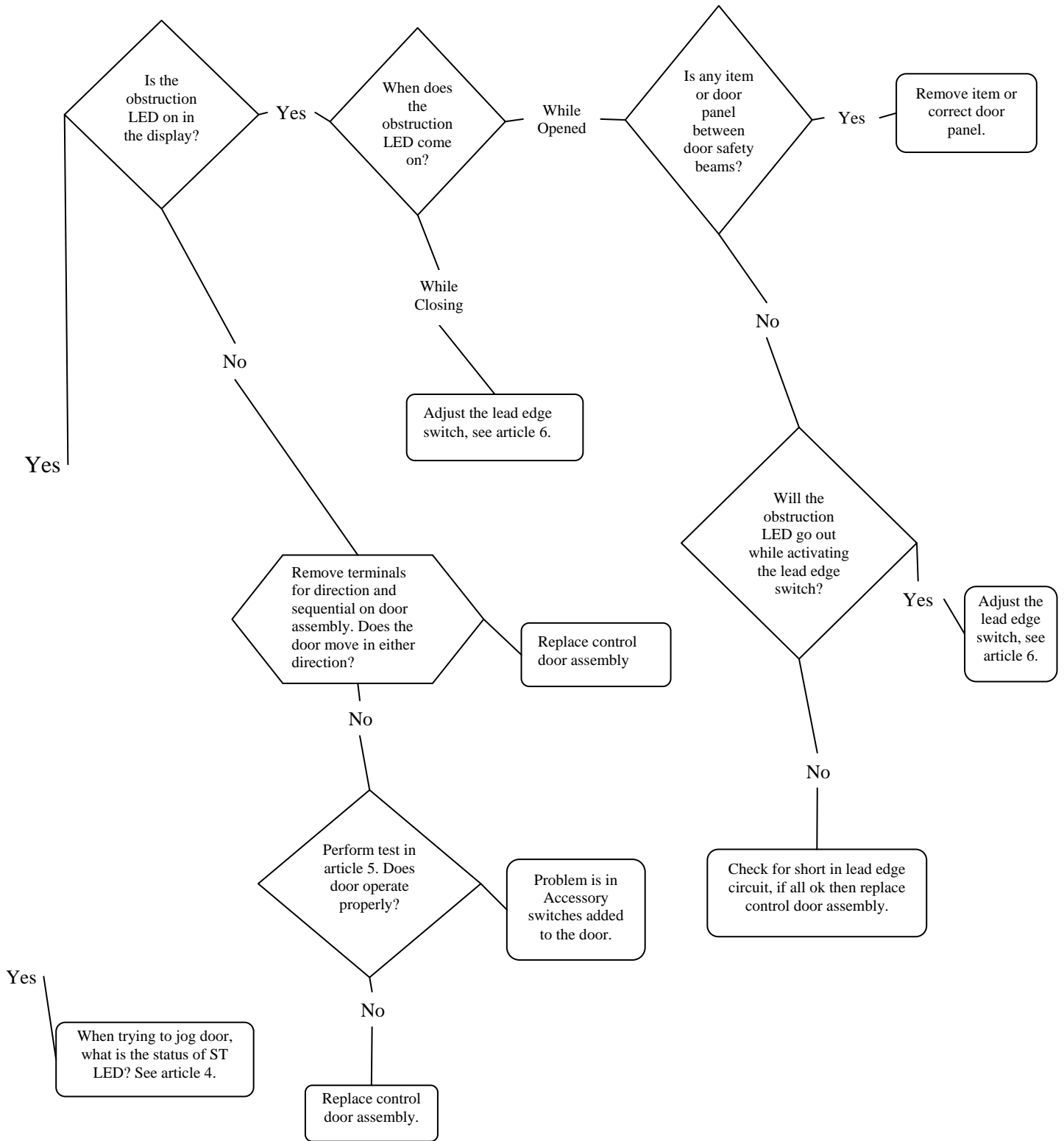

2.1 Article 1 - Unknown Position Indication

There are occasions when the controller may not know the exact position of the door, for example, when returning from the Jog Mode. In these cases the Display Indicator will display a series of three bars as shown at the right. This is known as the **Unknown Position Indication**.

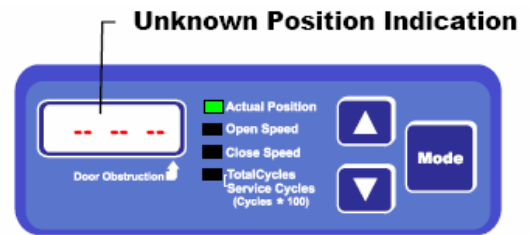

When the door is actuated, the door will proceed to the full open position, however the speed of the door will be reduced. When the door has returned from the home switch position to the open limit position, the display will show the actual position of the door. This indicates that the door has reset its position and is ready for normal operation.

If something in the door encoders fails the control will not be able to recognize the position of the door. This problem can also arise from a loose or bad connection in the DC harness. Check to make sure the harness is connected properly and that there aren't any loose wires in the connections of the encoders.

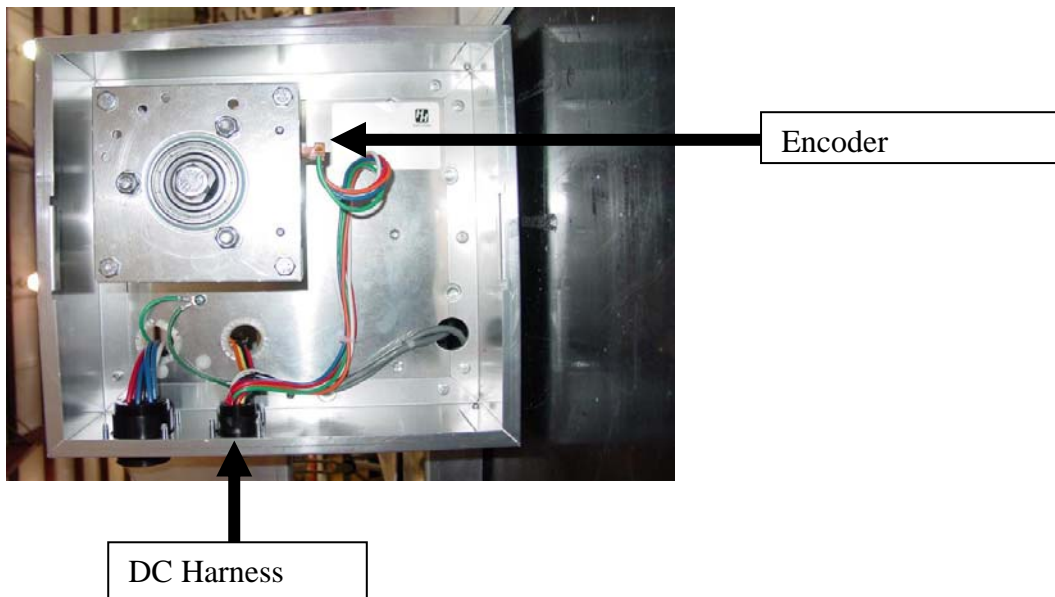
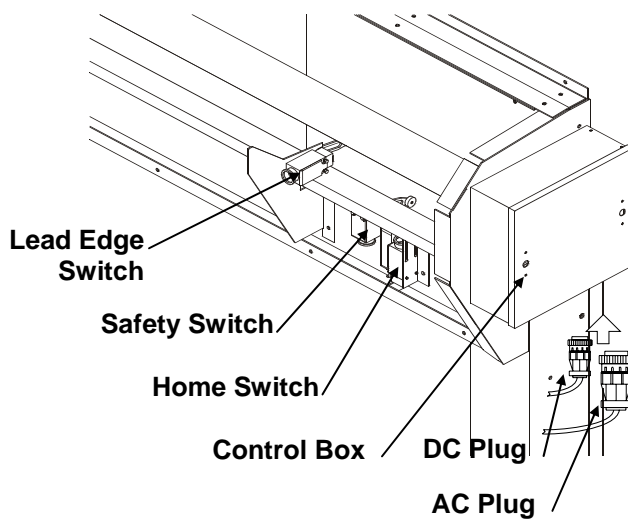

2.2 Article 2 - Error Codes

Mechanical Errors				
Code	Condition	Panel Movement	Problem Area	Possible Solutions
EO1	Opening, Home Switch		Home Switch	Try to activate door normally (open), should fix itself
				Use JOG mode to lower door panel below Home switch, See Article 3
				Manually release brake and pull panel below Home switch, See figure 1
				Home Switch Arm may be loose. Retighten, See Article 6
EC1	Closing, Home Switch		Home Switch	Lower limit is not set correctly, Reset door limits PS 1
				Home Switch Arm may be loose. Retighten, See Article 6
				Faulty connections, check DC harness at the RS 500 door and the DC connections on the PCB154 See figure 2 & 3
EO2	Opening, Safety Switch		Safety Switch	Safety Switch Arm may be loose. Retighten, See Article 6
				Faulty connections, check DC harness at the RS 500 door and the DC connections on the PCB154 See figure 2 & 3
EC2	Closing, Safety Switch		Safety Switch	Safety Switch Arm may be loose. Retighten, See Article 6
				Faulty connections, check DC harness at the RS 500 door and the DC connections on the PCB154 See figure 2 & 3
EO3	Opening, Safety Switch		Home & Safety	Manually release brake and pull panel below Home switch, See figure 1
				Check DC harness connection, especially if "Door Obstruction" LED is on. See figure 2.
EC3	Closing, Safety Switch		Home & Safety	Manually release brake and pull panel below Home switch
EC3				Check DC harness connection, especially if "Door Obstruction" LED is on. See figure 2.

Feedback Errors				
Code	Condition	Panel Movement	Problem Area	Possible Solutions
EOF1	Opening, Encoder Fault	Up or Down	Encoder	Check DC harness, make sure optics are clean, inspect encoder wire connections in door's junction box and on PCB154 control board. See figure 1 & 2
		None	Brake	To prove the brake is not releasing automatically, disengage manual brake release (See figure 1) and attempt to operate door. If it operates, one or more of the following is the problem.
			Brake Relay	Check brake relay on PCB154 control board. See Article 7
			Brake Rectifier	Check brake rectifier in gear motor. See Article 7
			Brake Assembly	Make sure brake is not adjusted too tight or that the brake assembly is defective, See figure 4
			Egress Strap	Check egress strap to ensure that the strap is in the correct reset Limit Mark position and not pulled out of position.
ECF1	Closing, Encoder Fault	Up or Down	Encoder	Check DC harness, make sure optics are clean, inspect encoder wire connections in door's junction box and on PCB154 control board. See figure 2 & 3
ECF1		None	Brake	To prove the brake is not releasing automatically, disengage manual brake release (See figure 1) and attempt to operate door. If it operates, one or more of the following is the problem.
			Brake Relay	Check brake relay on PCB154 control board. See Article 7
			Brake Rectifier	Check brake rectifier in gear motor. See Article 7
ECF1			Brake Assembly	Make sure brake is not adjusted too tight or that the brake assembly is defective, See figure 4
EOF2	Opening, Direction Fault	Up then panel stops and rolls down a few inches	Drive Overload Trip	If a drive overload occurs due to over-current, over-voltage, or temperature levels out of range, the drive may trip while the door is opening.
		Up	Encoder	Signal Wires (A, B) reversed. See figure 3
			Drive	Reverse two phases to the motor
		Down	Drive	The drive or the gear motor may not be functioning.
			Drive	If the gear motor seems to be functioning, then two phases to the motor must be reversed.
			Egress Strap	Check egress strap to ensure that the strap is in the correct reset Limit Mark position and not pulled out of position.
ECF2	Closing, Direction Fault	Up	Drive	Reverse two phases to the motor
		Down	Encoder	Signal Wires (A, B) reversed. See figure 3

Figure 1

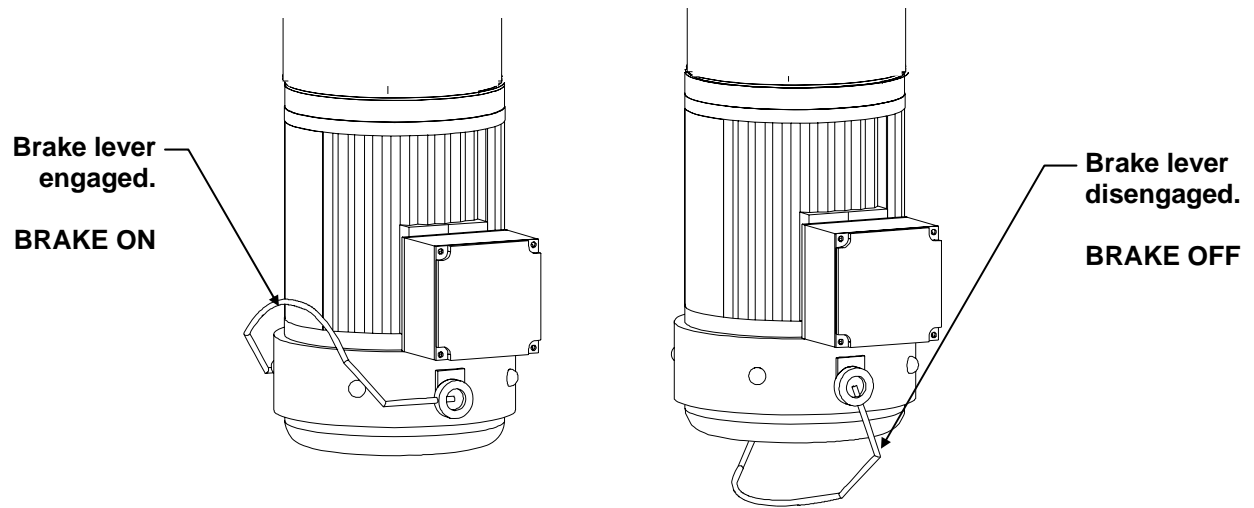

Figure 2

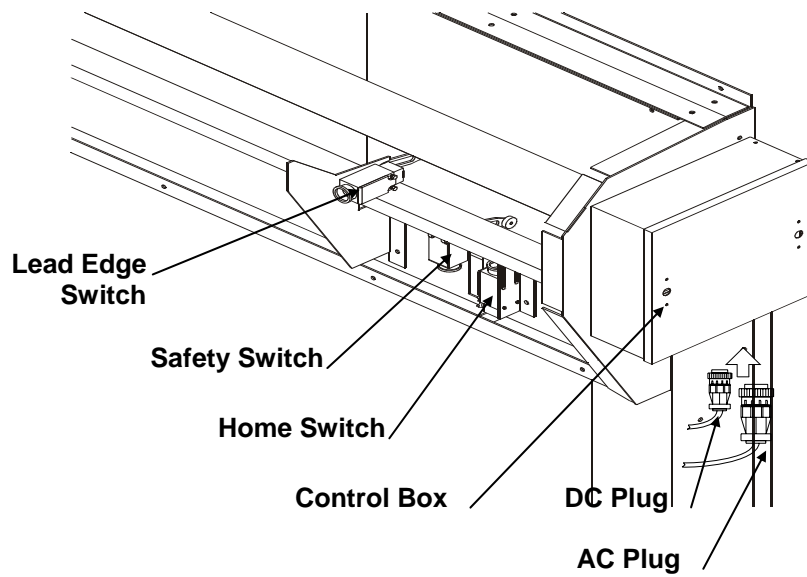
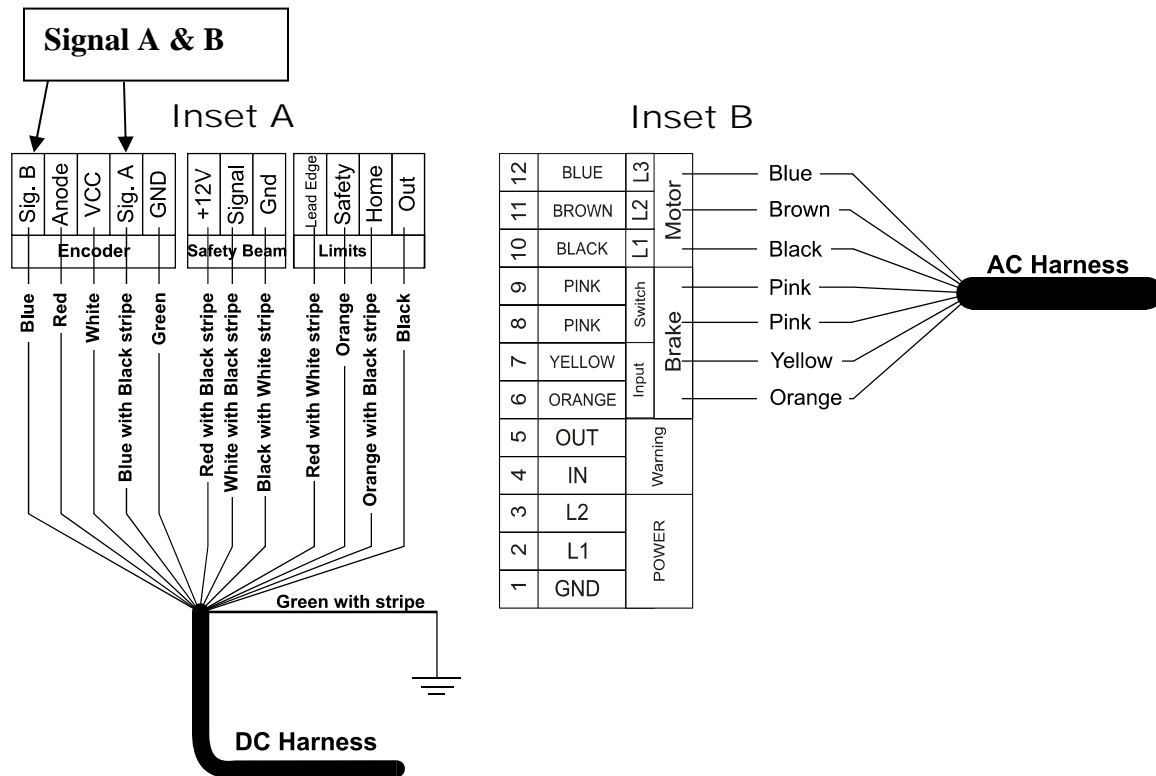
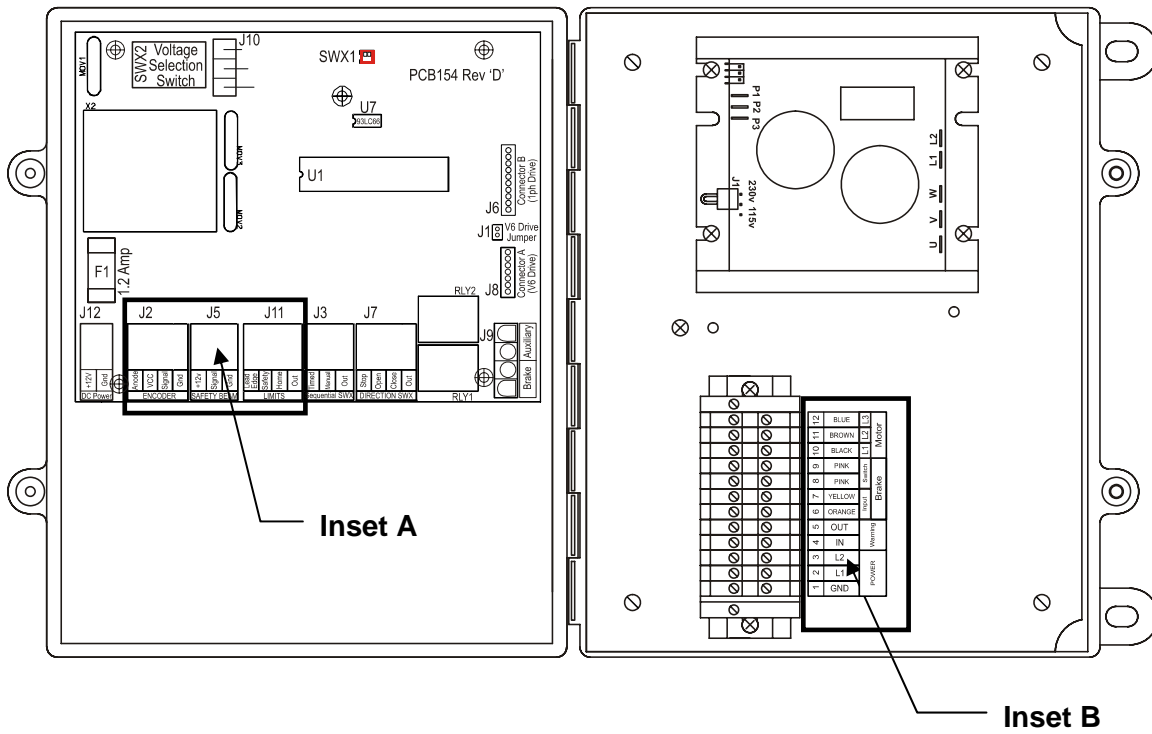

Figure 3

SC-325 - Right & Left Side Compartments



Adjustment of Brake

After extended operation of the brake lever, the brake may become worn. As the brake wears, some adjustment to the brake is required. Lettered diagrams below correspond to lettered instructions. Follow instructions to adjust brake:

1. Close door curtain to fully lowered position.
2. Engage Brake lever.
3. Disconnect electrical power to motor.
4. Remove four Phillips screws (**A**).
5. Remove cover (**B**).
6. Straighten the bent tab (**C**) of spider nut.
7. Tighten spider nut (**C**) snugly against blower wheel. Make sure a tab of spider nut is aligned with a notch in the shaft.
8. Bend tab (**C**) downward into notch of shaft.
9. Replace cover (**B**).
10. Replace four Phillips screws (**A**).
11. Disengage brake lever (**D**).
12. Adjustment complete.

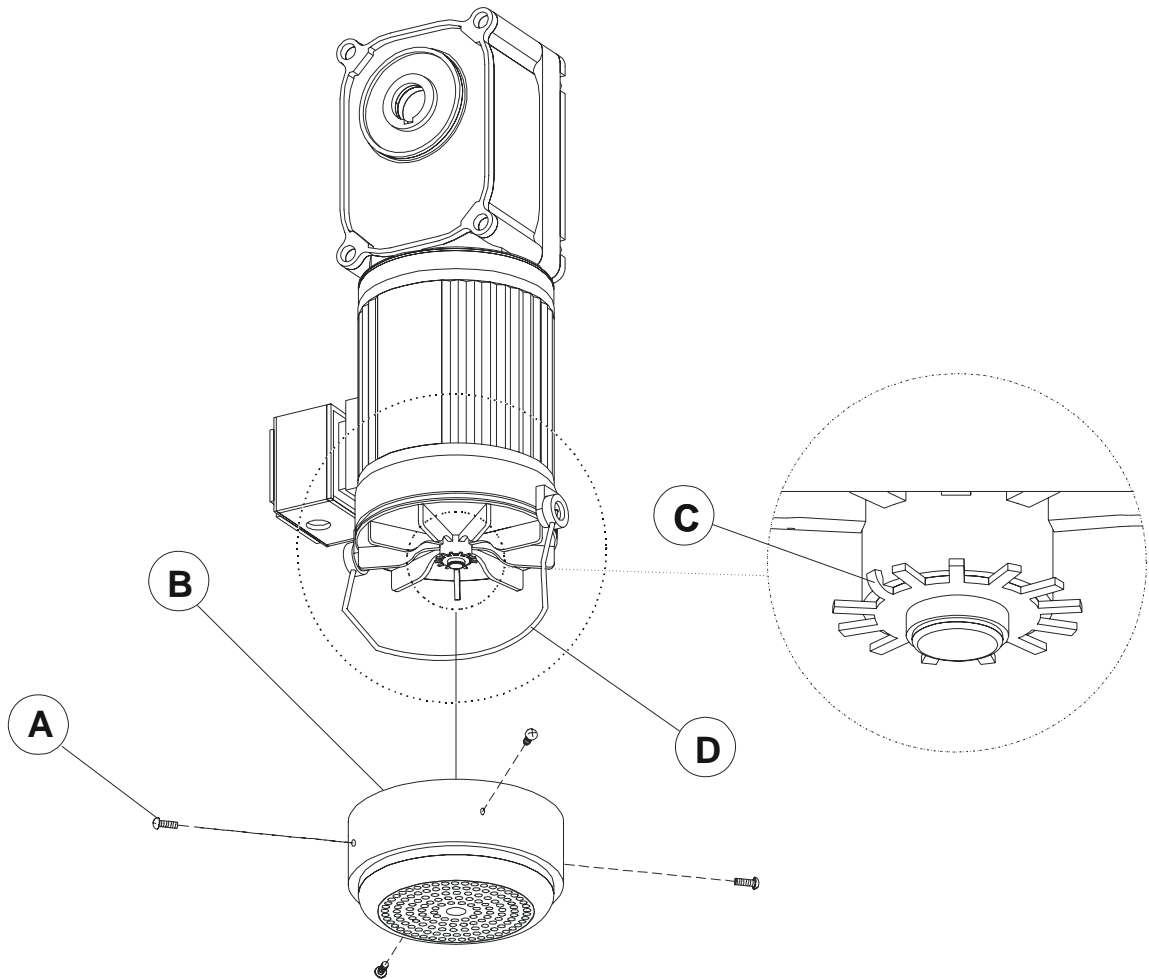

2.3 Article 3 - Jog Mode

The Jog Mode will permit an operator to manually control the position of the door with the **Up** (Δ) and **Down** (∇) arrow buttons. To enter the Jog Mode, press both the **Up** (Δ) and **Down** (∇) arrows at the same time for at least 5 seconds. The SC-325 will indicate the Jog Mode in the display as shown below.

In the Jog Mode the door can be opened and closed and is not affected by the Home limit switch or the Safety beam. Therefore, the operator must carefully watch the door movement when nearing the full open and full closed positions. To exit the Jog Mode, press and hold the **Up** (Δ) and **Down** (∇) arrow buttons for at least 5 seconds. The controller will return to the normal operating mode with the Actual Position shown in the display.

When returning to the normal operating mode, the SC-325 will not know the exact position that the operator has left the door when exiting the Jog mode. Therefore, the controller will display a series of three horizontal bars. Upon the next command the door will slowly proceed to the full open position to reset its memory. The door will always follow this procedure after exiting the Jog Mode.

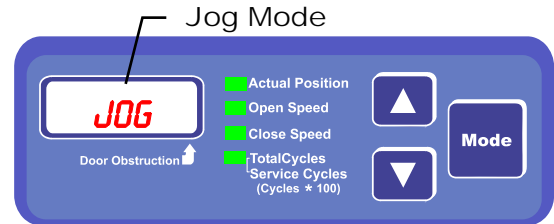

2.4 Article 4 - SC-325 Drive Diagnostic LEDs

KB Drive Diagnostic LEDs			
Door Idle			
PWR LED	ST LED	Operating Condition	Possible Causes
OFF	OFF	Drive is Off	No AC Power Applied
			Fuse Blown
			Defective Drive
Green	Steady Yellow	Normal Condition	
Green	Quick Flash Red/Yellow	AC Input Undervoltage	Input AC=115 Vac/Drive Jumper set on 230 Vac
Green	Slow Flash Red/Yellow	AC Input Overvoltage	Input AC=230 Vac/Drive Jumper set on 115 Vac
Green	Steady Red	Current Overload	Drive tripped due to current overload
Green	Red/Yellow/Green	Undervoltage or Overvoltage	Drive tripped due to out of range voltage condition
Door Moving			
PWR LED	ST LED	Operating Condition	Possible Causes
Green	Slow Flash Green	Normal Condition	
Green	Quick Flash Red	Overcurrent	Drive operating at 120%-200% of full rated load
Green	Slow Flash Red	Short Circuit	Two phases may be shorted
			Phase may be shorted to ground
			Gear motor may be defective

Slow Flash = LED flashes 1 second off, 1 second on

Quick Flash = LED flashes 0.25 second off, 0.25 second on

Steady = LED is constantly on



Status LED

2.5 Article 5 - Switch Testing

With the sequential switch and the direction switch terminal blocks removed all input signals are disabled. Any input signal to make the door operate will come from this test. For a quick overview there are two types of operator inputs that can be connected to the SC-325 controller for opening and closing the RS-500 door. They are directional input, and sequential input. Switches can be connected to one or both connections simultaneously to the SC-325 controller. The table below describes the response of the door when a specific operation of the door is being carried out and what the door does when a specific operator button has been pressed.

	<u>Manual Activated</u>	<u>Timed Activated</u>	<u>Open Activated</u>	<u>Close Activated</u>	<u>Stop Activated</u>	<u>Notes</u>
During the specific operation below.....						
<u>TIMED Opening</u>	N/A	N/A	N/A	N/A	Stops Door after 1-2 Seconds	
<u>TIMED Closing</u>	N/A	Reopens Door & Starts Delay	N/A	N/A	Stops Door (Immediately)	
<u>During TIMED Countdown</u>	Closes Immediately	Restarts Time Delay	Exits Time Delay	Closes Door	Should Terminate Timed Cycle	
<u>MANUAL Opening</u>	N/A	N/A	N/A	N/A	① Stops Door after 1-2 Seconds	① When Stop is pressed & door stops, pressing the Manual button again will cause the door to reverse direction at that point.
<u>MANUAL Closing</u>	N/A	Opens then starts Time Delay	N/A	N/A	① Stops Door (Immediately)	
<u>While Completely Open (after MANUAL)</u>	Closes	N/A	N/A	Closes Door	N/A	
<u>While OPENing</u>	N/A	N/A	N/A	N/A	Stops Door after 1-2 Seconds	
<u>While CLOSing</u>	N/A	Reopens door & starts Time Delay	N/A	N/A	Stops Door (Immediately)	

Directional Switch Input

The directional switch input is primarily for use with a three position direction switch similar to the one illustrated below. Operation is simple. Momentarily push “OPEN” to open the door, momentarily push “CLOSE” to close the door and momentarily push “STOP” to stop the door. However, the SC-325 controller can be programmed to perform special events with these directional switches. For example, if the “STOP” button is pressed and held, the door will remain in the stopped position. None of the other control switches will operate as long as the “STOP” connection to the controller is completed. Similarly, if the “OPEN” button is pressed and held, the door will remain in the open position. And, if the “CLOSE” button is pressed and held, the door will remain in the closed position. These features would be useful if an operator wanted to “lock” the door in a particular position with the use of external switches connected in parallel with the directional switch. *For safety reasons, these directional buttons have a priority built into the SC-325 controller in case one or more of the buttons are pressed at the same time. The “STOP” switch has first priority, the “OPEN” has second priority and the “CLOSE” has third priority.*

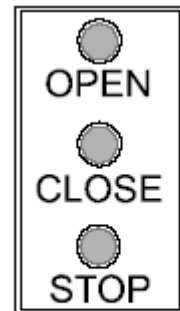

Three Position Operator Switch

Sequential Switch Input Manual (Single) Switch Input

This switch provides a conventional means of connecting a single button that responds to each momentary press sequentially. For example, if the last movement of the door was in the open direction and the manual input is made, the door will attempt to close.

Conversely, if the last movement of the door was in the close direction and the manual input is made, the door will attempt to open. If this single position manual switch is used with the three position directional switch as discussed above, the manual switch has fourth priority.

NOTE: This input will be reconfigured for use with the Interlock circuit if the P4 setting is programmed to anything other than zero. See Setting P4 under Section 6.1 for more information.

Timed Switch Input

The timed switch is intended for the connection of automatic door operating equipment, such as motion detectors or floor loops. The timed feature would be used when, for example, a vehicle (i.e. forklift) would open the door by means of a floor loop. Then, after the door is opened and all safety sensors are clear, a timer would count down and close the door automatically. In order for the timed feature to work, the door must have initially been in a closed or stopped position. If the door was already opened by some other means, the timer would not operate and the door would remain open.

The timed switch has priority five when the door is in the idle mode. However, if the door is in the process of closing, the timed input will act as a safety feature and that will stop and reverse the door until the door is fully opened.

For testing purposes the direction and sequential input terminals have been removed. This was done from a step in the trouble shooting flow chart.

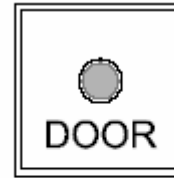

**Single Position
Operator Switch**

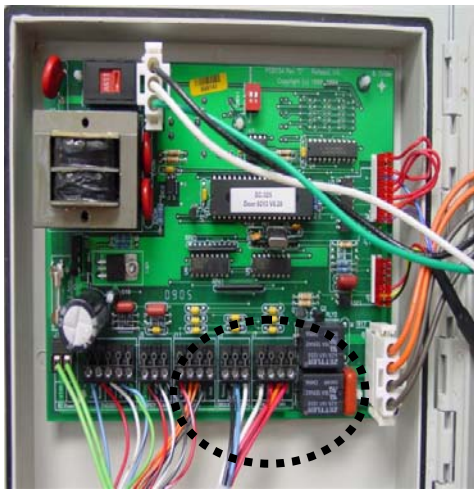

Test Direction SWX

To perform all tests below you must have a short piece of wire. This wire could be 5 inches long and can be 16/18 gage in size. Each test performed will be located in the same area of the PCB 154 of the door assembly as below.

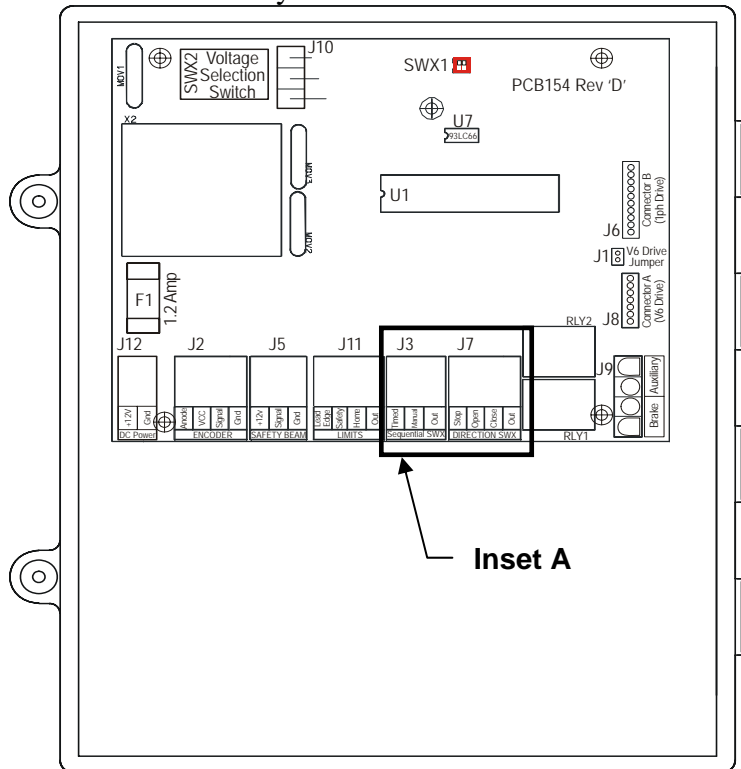

Inset A

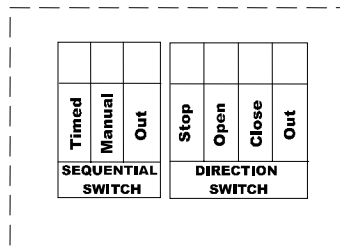

1. Test Open Direction

- a. Place the jumper on the pins of **Out to Open** momentarily. Care should be taken that this wire only touches these two points. The door should open to its full open position.

Inset A

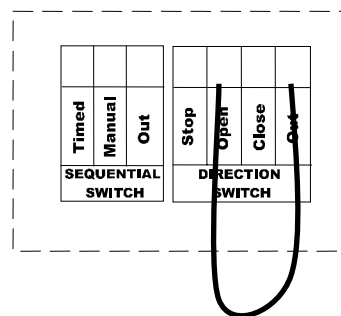

2. Test Close Direction

- a. Place the jumper on the pins of **Out to Close** momentarily. Care should be taken that this wire only touches these two points. The door should close to its full close position.

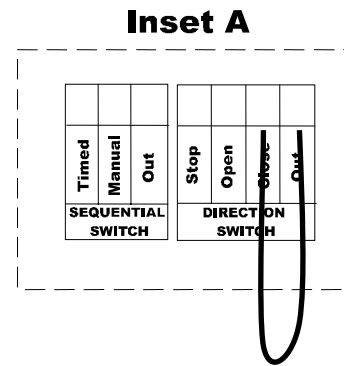

3. Test Stop Position

- a. Place the jumper on the open or close direction momentarily, the door will start to move in that direction. Care should be taken that this wire only touches these two points. Before the door gets to its full limit place the jumper across the **Out to Stop** position momentarily. The door should stop at this point.

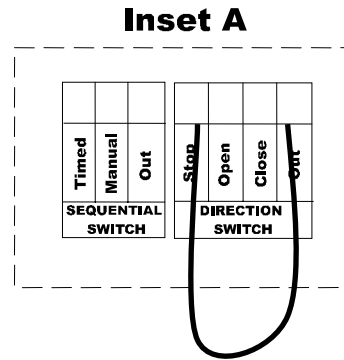

Test Sequential SWX

4. Test Manual Position

- a. Place the jumper on the pins of **Out to Manual** momentarily. Care should be taken that this wire only touches these two points. The door should open or close to its full limit position. The direction will depend on the last time it received an input from this location. Each time you make contact on this point the door will move opposite of the previous move.

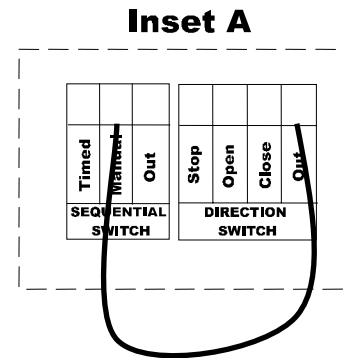

5. Test Timed Direction

- a. The door must be closed before performing this test. Place the jumper on the pins of **Out to Timed** momentarily. Care should be taken that this wire only touches these two points. After the door is opened and all safety sensors are clear, a timer would count down and close the door automatically. In order for the timed feature to work, the door must have initially been in a closed or stopped position. If the door was already opened by an open test or some other means, the timer would not operate and the door would remain open.

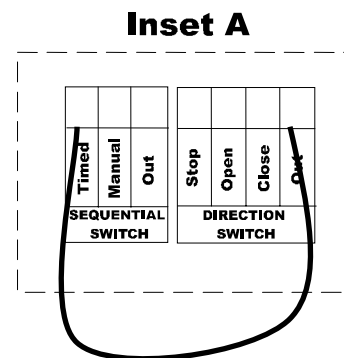

2.6 Article 6 - Adjusting the HOME, Safety, and Lead Edge Switches

At some point it may be necessary to adjust one of the three switches located within the horizontal member mechanism of the door. These switches are attached to levers that contact the curtain. The **home switch** sets the 'open' position of the door curtain. When the curtain is raised, the home switch limits the height to which the curtain opens. The **safety switch** is a failsafe switch that stops the curtain in the unlikely event of malfunction of the home switch. NOTE when the safety switch is activated the door will no longer operate until corrected. The **lead-edge switch** is a switch that stops the curtain in the event of a doorway obstruction. The control will indicate these switches out of position with an error code in the display. The lead edge switch out of position will be indicated with the obstruction led in the display. For the correct position of these switches, normal settings will be without the roller arm having contact with the panel.

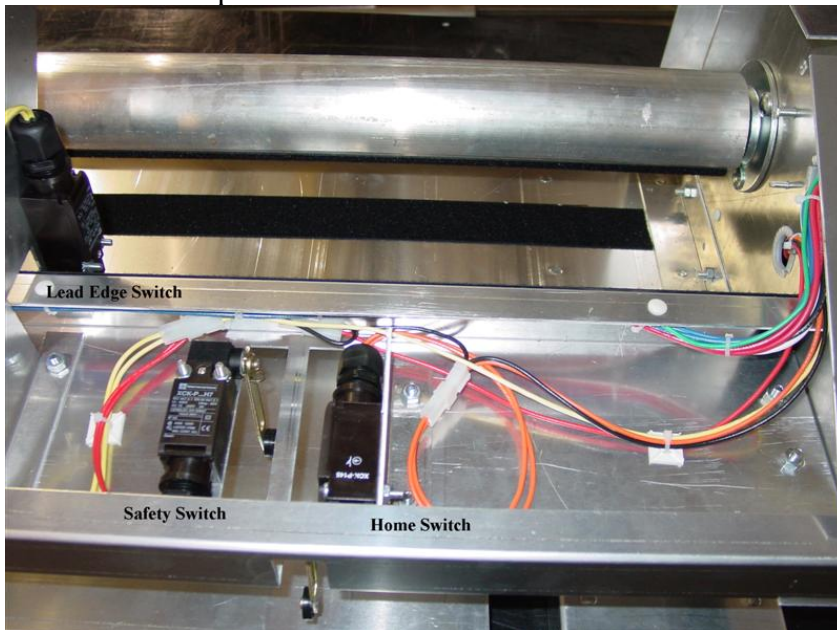

Adjust the home switch at 90 degrees from its mounted position.

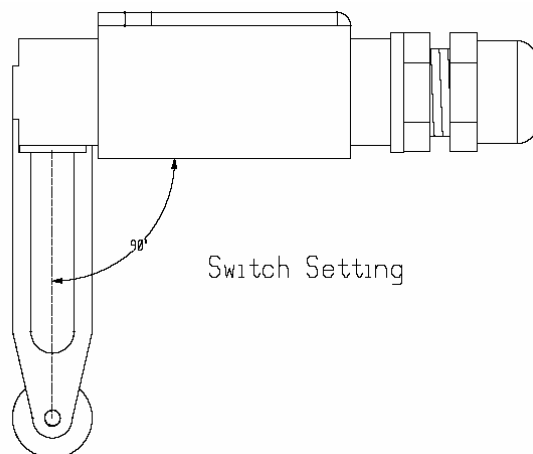

Adjust the safety switch at 90 degrees from its mounted position.

The lead edge switch has been installed in two different ways therefore the switch will need setting different depending on the way the switch was mounted. The first type was used through 2005. Starting January 2006 the switch was mounted different, requiring a different setting. Notice the difference in the two different brackets used and how the switch is mounted to it.

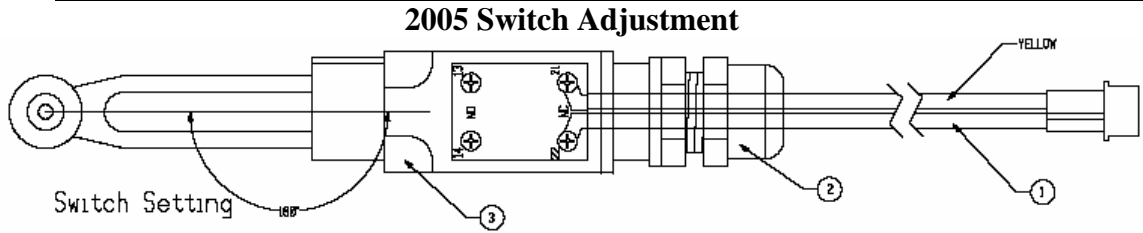
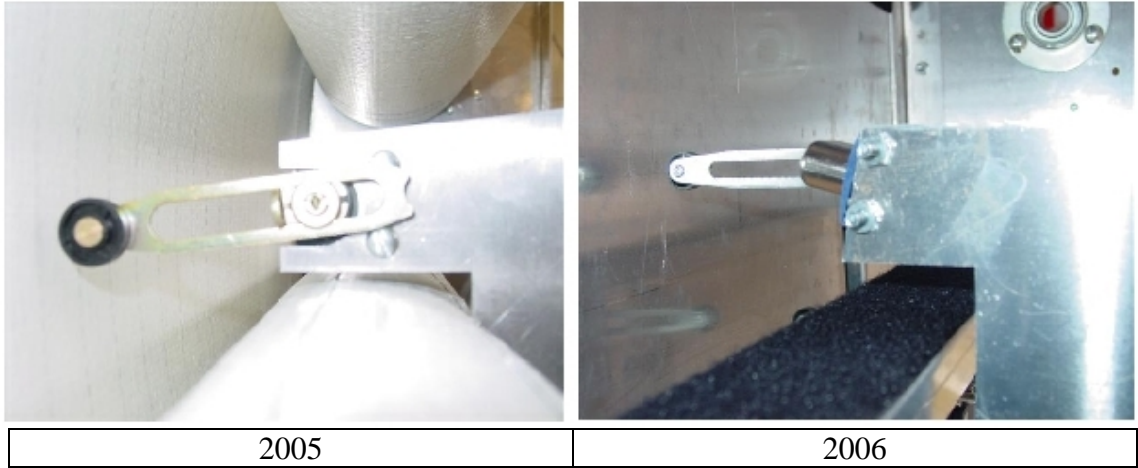

Adjust the lead edge switch at 180 degrees from its mounted position.



2006 Switch Adjustment

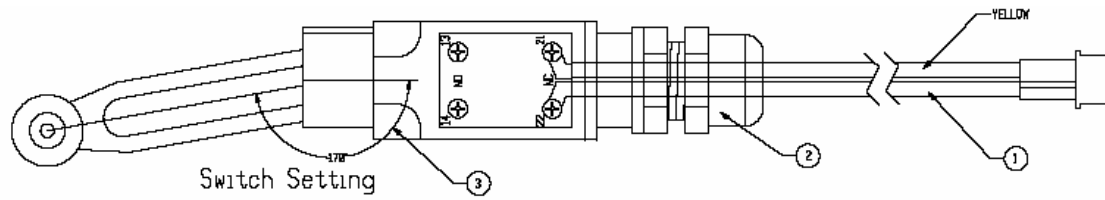

Adjust the lead edge switch at 170 degrees from its mounted position.

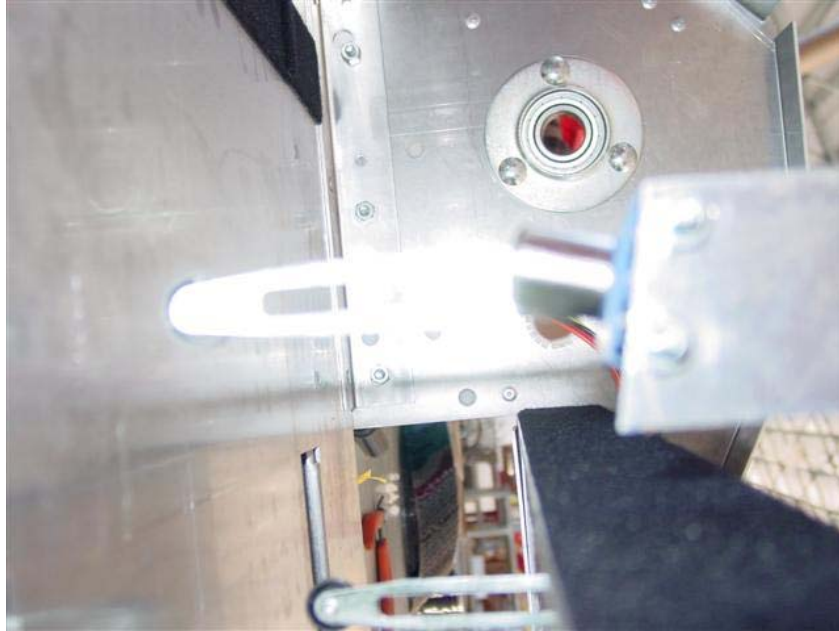

After adjusting the lead edge switch make sure it is positioned downward against the door panel.



2.7 Article 7 - Test Brake Relay

The gear motors on these RS 500/600 series door has a brake rectifier which will activate the brake in the gear motor to stop the unit when not in use. There is a relay (acting as a switch) on the PCB 154 board in the door assembly of the control that will turn this brake on and off. This test procedure will allow you to test the relay to see if it is failing or if the problem could be in the brake rectifier. First we need to test the brake relay on the PCB 154. The connections are found at the bottom right corner of the board.

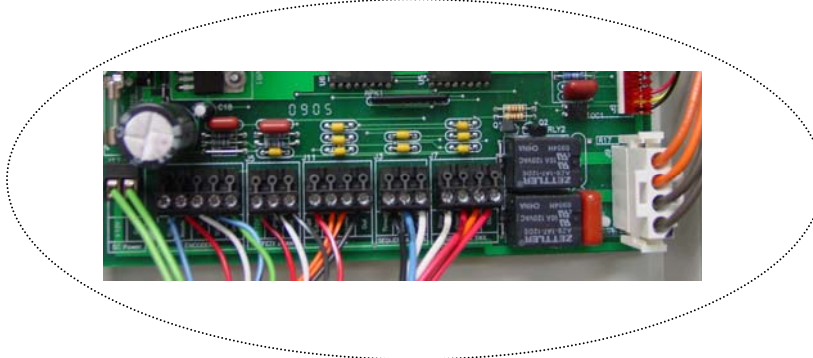
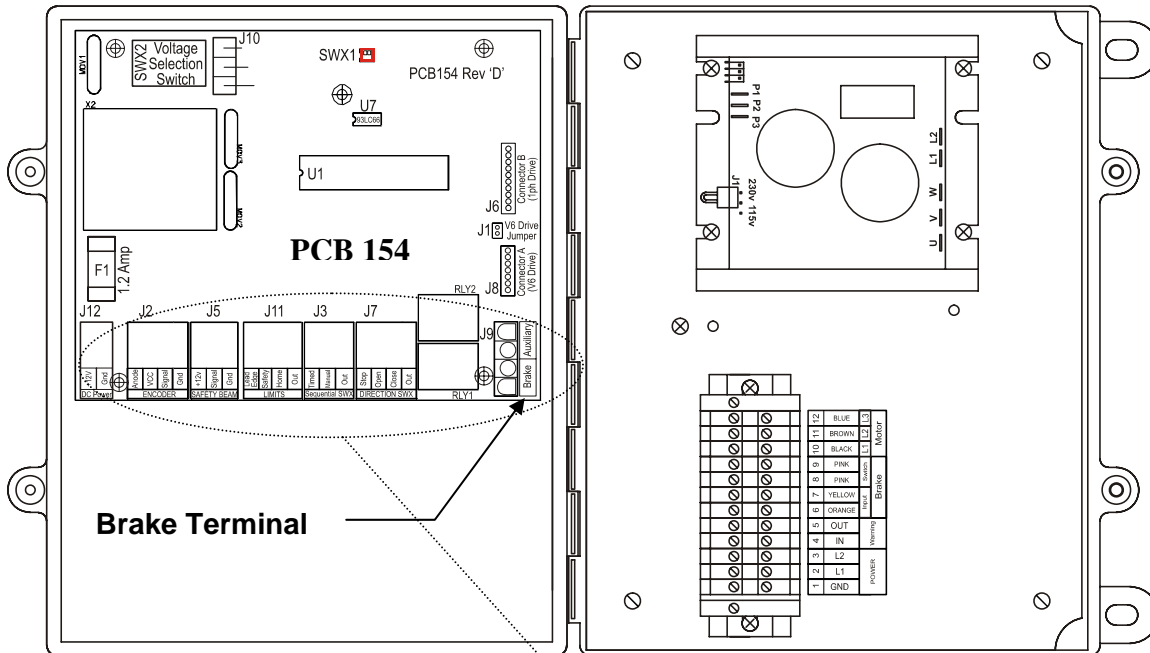

If the brake relay is at fault the door will struggle to operate or it could cause the drive board to trip and there would be an Error code of EOF1 or ECF1 in the display of the control.

To test the brake relay:

1. Remove quick connect connector from the PCB 154 board.
2. The door must be operated in one direction while in the jog mode. See Article 3.
3. While pressing the up or down arrow while in jog mode place a jumper across the connectors inside the quick connect which will act as a switch like the relay would normally do. See figure 1.

This should release the brake and allow the door to operate. If the door does operate after performing step three then replace the door assembly of the control.

The brake rectifier is a device in the doors' gear motor junction box. This brake rectifier is supplied voltage from the controller. The brake rectifier is activated by a brake relay on the PCB 154 controller board.

When the controller supply voltage is 115 VAC and a 3017-5052 A-100 brake rectifier is installed inside the door gear motor junction box, the output brake voltage should be approximately 100 VDC loaded and approximately 110 VDC unloaded.

When the controller supply voltage is 230 VAC and a 3017-5050 A-200 brake rectifier is installed inside the door gear motor junction box, the output brake voltage should be approximately 100 VDC loaded and approximately 177 VDC unloaded.

NOTE: Loaded = Connected to the gear motor brake; Unloaded = Not connected to the gear motor brake.

When this brake rectifier is activated it will supply the output brake voltage to the brake inside the gear motor and the brake will be released. The yellow and white wires on the brake rectifier are where voltage is supplied to the brake rectifier. This voltage is dependent on what type of power supply was given to the controller either 115 VAC or 230 VAC. The two blue wires on the brake rectifier are the activation connections. When these two wires touch each other, the brake rectifier is activated and the brake rectifier output voltage will leave the brake rectifier on the black and red wires.

Motor Brake Rectifier Wiring Diagram



HH p/n: 3017-5050
A200-D90-UL
 (for 200~230 VAC)

HH p/n: 3017-5052
A100-D90
 (for 100~120 VAC)

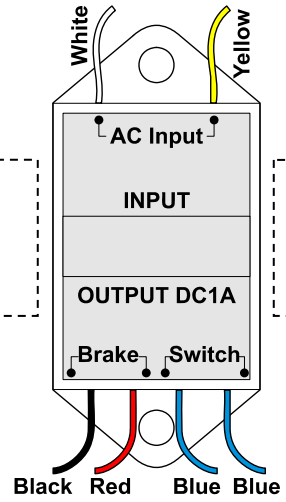

The **SC-325 controllers** are factory preset to 115 VAC and the **RS-500 doors** factory prewired to require a 115 VAC power supply.

The **SC-650 controllers** are factory preset to 230 VAC and the **RS-600 doors** factory prewired to require a 230 VAC power supply.

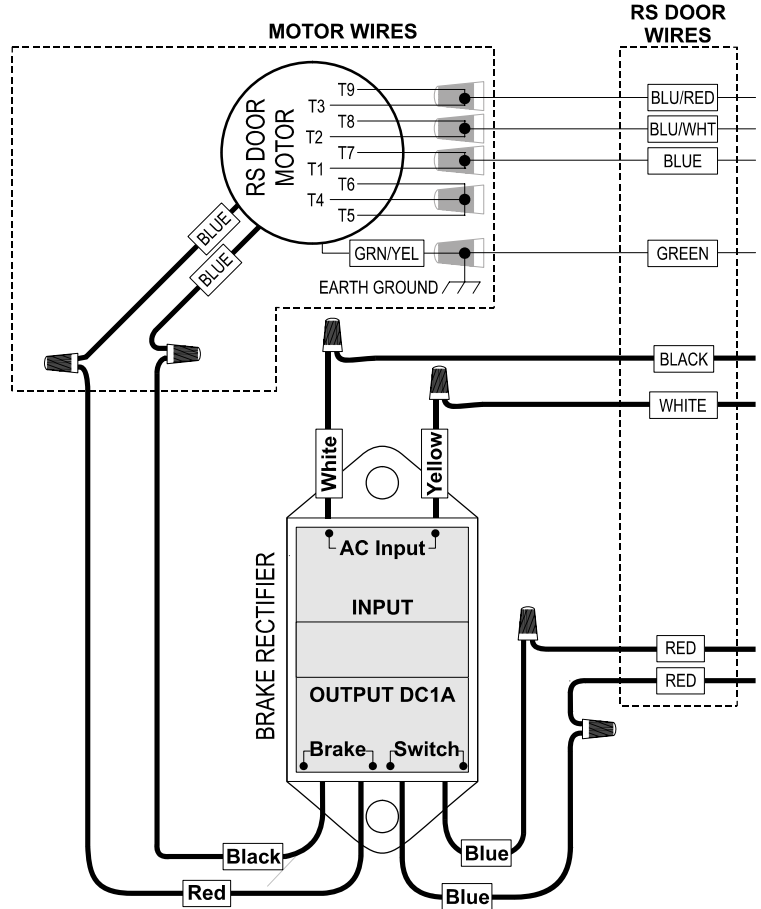

The SC-325/SC-650 controllers and RS-500/600 doors can be field upgraded to accommodate either 115 VAC or 230 VAC power supply. If the desired power supply voltage is different from the factory preset/prewired voltage, the appropriate version Brake Rectifier must be ordered separately, field-installed on the RS Door, and the SC controller switch & jumper settings changed accordingly.

⚠WARNING!
 Dangerous High Voltages!
 Allow Approximately 5 Minutes For The Controller To Power-Down Before Changing Switch Settings, Jumper Placement, Or Wiring.

⚠WARNING!
 Use The Correct RS Door Brake Rectifier For The Specific Required Voltage!
 Using a 230 VAC brake rectifier with a 115 VAC power supply can result in improper door operation due to the mechanical brake not releasing properly. Using a 115 VAC brake rectifier with a 230 VAC power supply can result in damage to the mechanical brake and/or brake rectifier resulting in door failure.

3. RollSeal Automatic Door Wiring Diagram

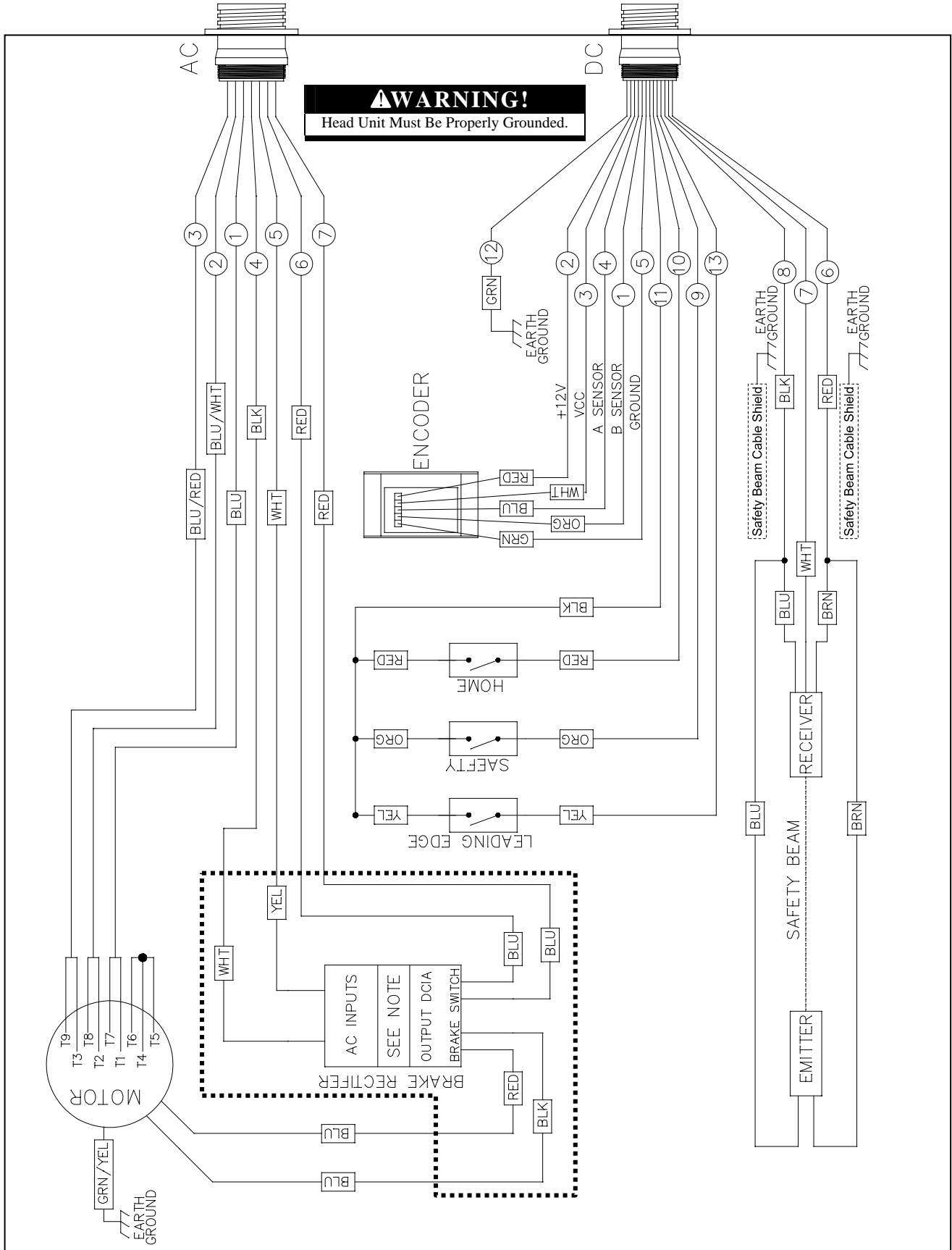

4. RollSeal Smart Controller Wiring Diagram

