

RS-500 Door

Installation Manual

RollSeal
PO Box 140
1751 County Road 68
Bremen, Alabama 35033

Table of Contents

1.	Ratings and Specifications.....	3
2.	Warnings (Avertissements)	4
3.	Limited Warranty.....	8
4.	Physical Description/Drawing	9
5.	Use of Equipment	9
6.	Installation	9
6.1	Tools Required.....	9
6.2	Overview	9
6.3	Adjusting the Clear Opening.....	10
6.4	Attachment Points of Door	11
6.5	Assembly of Parts	12
6.6	Infrared Sensor Connectors.....	13
6.7	Fastening Door Assembly to Clear Opening.....	13
6.8	Connecting the Electrical Power	15
7.	Operation of Door	15
8.	Limit Switches	15
9.	Manual Operation of Door.....	16
9.1	Operating Instructions	16
9.2	Adjustment of Brake	17
10.	Emergency Egress.....	18
11.	Egress Strap Removal/Re-Installation.....	20
12.	Door Panel Adjustments.....	21
13.	Removal of Existing Panel	22
14.	Installation of Replacement Panel.....	23
15.	RS 500 Door Wiring Diagram	24
16.	RollSeal Smart Controller Wiring Diagram.....	25

Please Retain This Manual for Future Reference

1. Ratings and Specifications

- Motor Rating.....240 VAC, Three Phase, 1/4 hp
- Motor must be connected through controller. See RS SC-325 Manual (4801-5156).

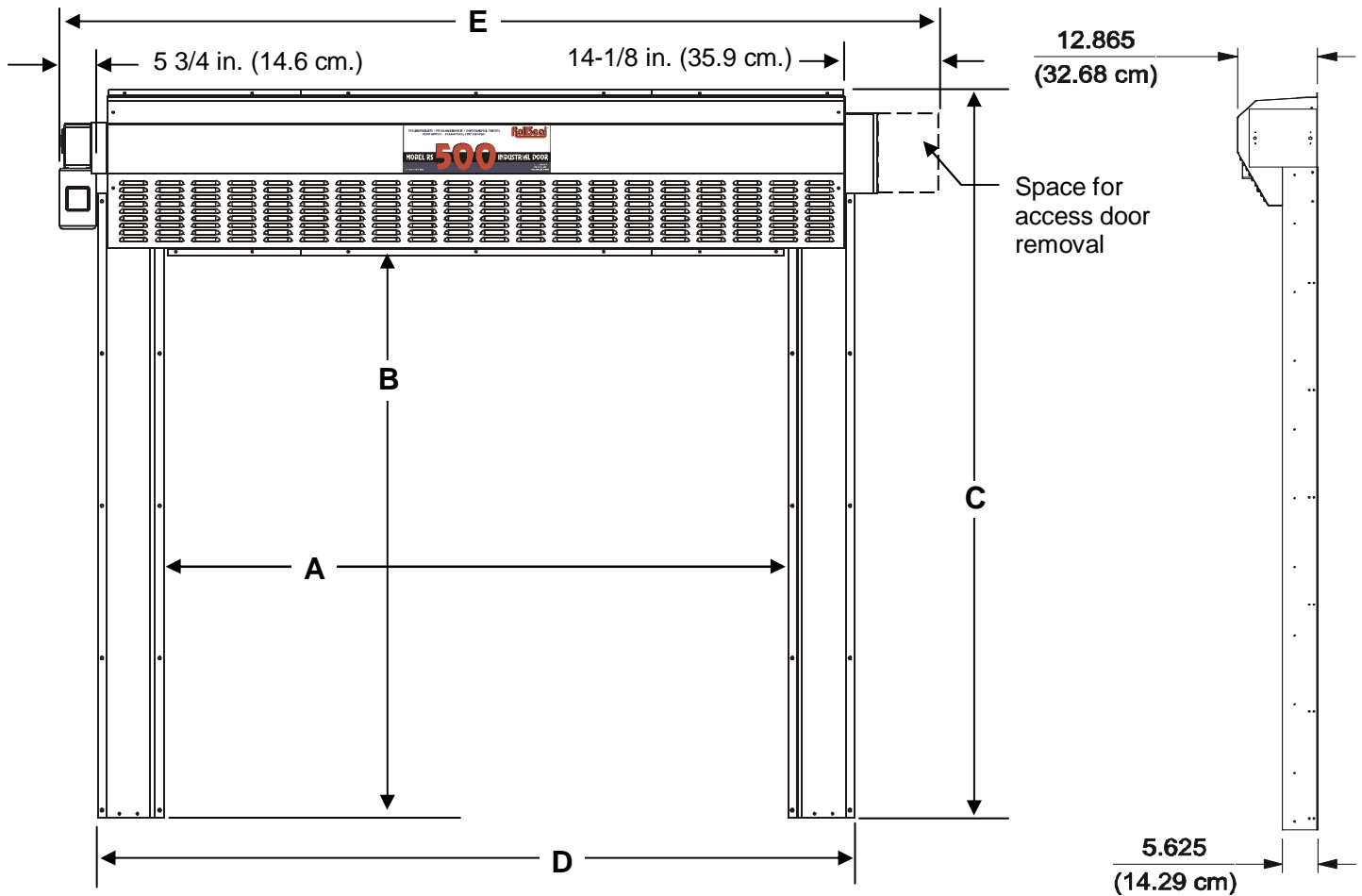

TABLE 1 RS 500 Door Standard Dimensions:

WIDTH Related Dimensions

RS500 Door Width	A			D			E		
	Ft.	In.	cm	Ft.	In.	cm	Ft.	In.	cm
4'(W)	4	0	122	5	4-13/32	164	6	8-15/16	206
5'(W)	5	0	153	6	4-13/32	194	7	8-15/16	236
6'(W)	6	0	183	7	4-13/32	225	8	8-15/16	267
6'6"(W)	6	6	198	7	10-13/32	240	9	2-15/16	282
7'(W)	7	0	214	8	4-13/32	255	9	8-15/16	297
8'(W)	8	0	244	9	4-13/32	286	10	8-15/16	328
10'(W)	10	0	305	11	4-13/32	347	12	8-15/16	388
11'(W)	11	0	335	12	4-13/32	377	13	8-15/16	419
12'(W)	12	0	366	13	4-13/32	408	14	8-15/16	449

HEIGHT Related Dimensions

RS500 Door Height	B			C		
	Ft.	In.	cm	Ft.	In.	cm
7'(H)	7	0	214	8	8-11/16	266
7'6"(H)	7	6	229	9	2-11/16	281
8'(H)	8	0	244	9	8-11/16	296
9'(H)	9	0	275	10	8-11/16	327
10'(H)	10	0	305	11	8-11/16	357
11'(H)	11	0	335	12	8-11/16	387
12'(H)	12	0	366	13	8-11/16	418

2. Warnings (Avertissements)

Warning!

Disconnect All Power Sources Before Installing This Equipment. Failure To Disconnect Power Source Can Result In Property Damage, Serious Injury Or Death!

Warning!

Dangerous Rotating Machinery!
Keep Hands, Clothing, Etc. Clear When Operating!
Do Not Operate Without All Guards And Covers In Place!

Warning!

All Wiring Should Be In Accordance with National Electrical Codes Or Other Local Codes.

Warning!

The Installer Is Responsible For Complying With All Relevant Regulations, Such As National Wiring Regulations And Accident Prevention Regulations. Particular Attention Must Be Given To The Cross-sectional Areas Of Conductors, The Selection Of Fuses Or Other Protection, And Protective Earth/Ground Connections!

Warning!

The Voltages In The Power Cables And Certain Parts Of The Drive Can Result In Death. Whenever The Drive Has Been Used It Must Be Isolated And Disconnected For 5 Minutes Before Any Work Commences.

Danger!

Only Qualified Electrical Personnel Familiar With The Construction And Operation Of This Equipment And The Hazards Involved Should Install, Adjust, And/Or Service This Equipment. Read And Understand This Manual In Its Entirety Before Proceeding. Failure To Observe This Precaution Could Result In Severe Bodily Injury Or Death!

IMPORTANT INSTALLATION INSTRUCTIONS

WARNING!

To reduce the risk of severe injury or death:

1. READ AND FOLLOW ALL INSTALLATION INSTRUCTIONS.
2. Do not connect the door operator to the source of power until instructed to do so.
3. Locate the control station: (a) within sight of the door, (b) at a minimum height of 5 feet so small children cannot reach it, and (c) away from all moving parts of the door.
4. For products having a manual release, instruct the end user on the operation of the manual release.

IMPORTANT SAFETY INSTRUCTIONS

WARNING!

To reduce the risk of severe injury or death:

1. READ AND FOLLOW ALL INSTRUCTIONS!
2. Never let children operate or play with door controls. Keep the remote control (where provided) away from children.
3. Personnel should keep away a door in motion and keep the moving door in sight until it is completely closed or opened. **NO ONE SHOULD CROSS THE PATH OF A MOVING DOOR.**
4. Test the door's safety features at least once a month. After adjusting either the speed or the limit of travel, retest the door operator's safety features. Failure to adjust the operator properly may cause severe injury or death.
5. For products having a manual release, if possible, use the manual release only when the door is closed. Use caution when using this release when the door is open.
6. **KEEP DOORS PROPERLY OPERATING AND BALANCED.** See Door Manufacturer's Owner's Manual. An improperly operating or balanced door can cause severe injury or death. Have trained door systems technician make repairs to cables, spring assemblies, and other hardware.
7. **SAVE THESE INSTRUCTIONS.**

French Translated Warnings



Avertissement!

Disjoindre fournissent de l'énergie tout les sources avant qu'installer cet équipement. F|ailure| à disjoindre la source de pouvoir peut résulter dans dommage de propriété, blessure sérieuse ou mort !



Avertissement !

Mécanisme tournant dangereux !
Garder les mains, vêtissant, etcC|lear| quand fonctionner !
Ne fonctionnez pas sans toutes gardes et couvertures dans lieu !



Avertissement !

Tout montage sur fil de fer doit être selon codes électriques nationaux ou autres indicatifs régionaux.



Avertissement !

L'Installer est responsable pour conformer avec tout règlement pertinent, telles que règlement et règlement de prévention d'accident de montage sur fil de fer nationaux. Pl'attention articulaire doit être donnée pour les aires sectionnelles transversales de conducteurs, le choix d'elles fusées ou autre protection, et terre / prises de terre protecteur !



Avertissement !

Les tensions dans le pouvoir câblent et certains parties de la promenade en voiture peuvent résulter dans la mort. W|e |henever| la promenade en voiture a été utilisé il doit être isolé et détaché pendant 5 procès avant que tout travail commence.



Danger !

Seulement familier électrique de personnel qualifié avec la construction et opération de cet équipement et les hasards ont enveloppé devoir installer, arranger, et/ou - la révision cet équipement. R|ead| et comprendre ce manuel en entier avant que procéder. F|ailure| à observer cette précaution peut résulter dans dommage corporel sévère ou mort !

LES INSTRUCTIONS D'INSTALLATION IMPORTANTES

⚠️ AVERTISSEMENT!

À réduire le risque de blessure sévère ou mort:

1. LU ET SUIVENT TOUTES INSTRUCTIONS D'INSTALLATION.
2. Ne liez pas l'opérateur de porte per la source de pouvoir jusqu'à instruit faire ainsi.
3. Localisez la station de commande: (a) en vue de la porte, (b) à un minimum la hauteur de 5 pieds ainsi petit enfants ne peuvent pas l'atteindre, et (c) loin de tous parties en mouvement de la porte.
4. Pour produits ayant un délivrance manuelle, instruire l'utilisateur final sur l'opération de la délivrance manuelle.

RÈGLEMENTS DE SÉCURITÉ IMPORTANTS

⚠️ AVERTISSEMENT!

À réduire le risque de blessure sévère ou mort:

1. LU ET SUIVENT TOUTES INSTRUCTIONS!
2. Jamais laisser fonctionner enfants ou mouvoir vivement avec les autorités de porte. Gardez la télécommande (où a fourni) loin des enfants.
3. Le personnel devrait garder loin une porte dans mouvement et subsistance la porte en mouvement dans vue jusqu'à est complètement fermé ou avoir ouvert. **CES AUCUNS DOIVENT CROISER LE CHEMIN D'UNE PORTE EN MOUVEMENT.**
4. Éprouvez les traits de sécurité de la porte au moins une fois par mois. Après qu'arrangeant la vitesse ou la fin de course, retest les traits de sécurité de l'opérateur de porte. Manque à arranger l'opérateur correctement peut causer blessure sévère ou mort.
5. Pour produits ai manuel la délivrance, si possible, utiliser la délivrance manuelle seulement quand la porte est fermée. Précaution d'utilisation à utiliser cette délivrance quand la porte est ouverte.
6. **GARDER LES PORTES CORRECTEMENT QUI OPÈRE ET ÉQUILIBRÉ.** Voir la porte fabricant propriétaire manuel. Un improprement qui opère ou balancé porte peut causer blessure sévère ou mort. Formez les technicien de systèmes de porte faites les réparations per les câbles, réunions de source, et autre quincaillerie.
7. **SAUVEZ CES INSTRUCTIONS**

3. Limited Warranty

All products are warranted to be free from defects in material and workmanship for a period of one (1) year or 100,000 cycles, whichever occurs first, from the date of purchase if installed and used in strict accordance with the installation instructions. Liability is limited to the sale price of any products proved to be defective or, at manufacturers' option, to the replacement of such products upon their return. No products are to be returned to the manufacturer, until there is an inspection and/or a return-goods authorization (RGA) number is issued.

All complaints should be directed first to the authorized distributor who sold the product. If satisfaction is not obtained or the name of the distributor is not known, write the manufacturer that appears below, directed to the attention of Customer Service Manager.

This limited warranty is expressly in lieu of any and all representations and warranties expressed or implied, including any implied warranty of merchantability or fitness for a particular purpose. The remedy set forth in this limited warranty shall be the exclusive remedy available to any person. No person has authority to bind the manufacturer to any representation or warranty other than this limited warranty. The manufacturer shall not be liable for any consequential damages resulting from the use of our products or caused by any defect, failure or malfunction of our products. (Some areas do not allow the exclusion or limitation of incidental or consequential damages, so the above limitation or exclusion may not apply to you.)

This warranty gives you specific legal rights and you may also have other rights that vary from area to area.

Warrantor:

RollSeal
PO Box 99
1733 County Road 68
Bremen, Alabama 35033
Phone 256-287-7000



4. Physical Description/Drawing

Installation of a RollSeal RS-500 Automatic Door involves, at a minimum, connecting to the Smart Controller (SC)-325 that connects to the AC power, the door motor, the Up/Down button, and the safety beam. Other accessories can be added such as a remote IR sensor, a remote radio link, and door movement indicators such as lights and bells.

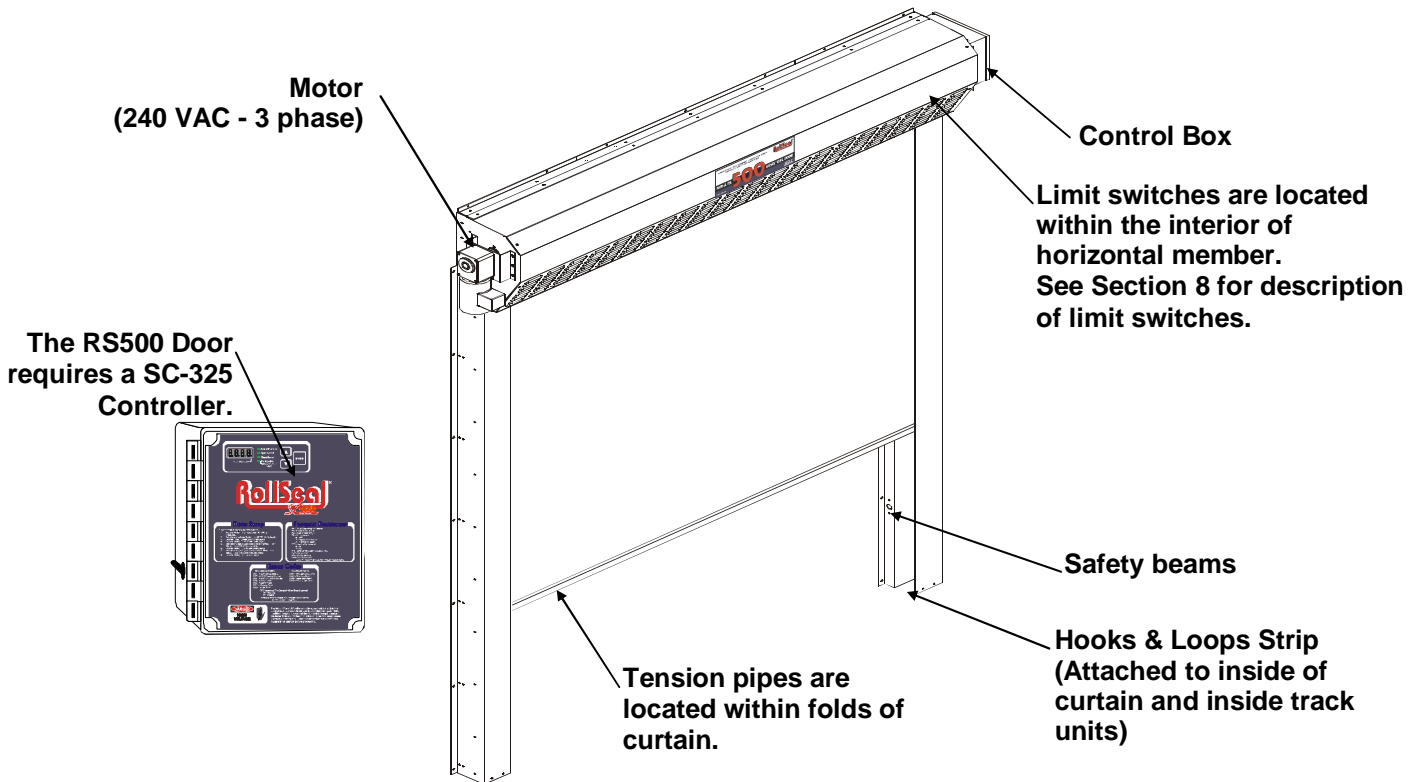

5. Use of Equipment

The RollSeal RS-500-Door is an automatic motorized curtain enclosure for a doorway.

6. Installation

6.1 Tools Required

3/8 in. (10 mm) Power screwdriver (portable)	Socket
3/16 in. (5 mm) Drill bit and power drill	Hammer
3/8 x 1 in. Bolts and nuts (supplied)	Tape measure
	Carpenter's level
<i>NOTE: Other Tools May Be Required According To Installation.</i>	

6.2 Overview

The RS-500-door is shipped with pre-assembled vertical members (left track and right track), and a pre-assembled horizontal member (head unit). Identify components by the Parts/Assemblies section in back of this manual. When components are received, check for damaged or loose or missing parts. If there are damaged or missing parts contact your RollSeal distributor immediately. Please read and understand all instructions in this manual before beginning installation.

6.3 **Adjusting the Clear Opening**

Locate your particular system in **Table 1**, page 1. Read the value of height and width of the clear opening for the door size that you are installing. This gives the required dimensions of the clear opening. If necessary, adjust the dimensions of the mounting posts or framing members to the height and width of your RS-500 door system as shown in **Diagram 1**. Refer to **Section 6.4 (page 8, Diagram 2)** for details of attaching door to framing members. Framing material must provide suitable support for attachment of screws.

Make sure that mounting posts or framing members are positioned so that the screw holes of the outer flanges of the vertical members will align with the mounting posts or framing members (**Section 6.4, page 8, Diagram 2**). Make sure that there is room for the motor and control box without encountering any obstructions.

Diagram 1
Front View (Curtain Side)

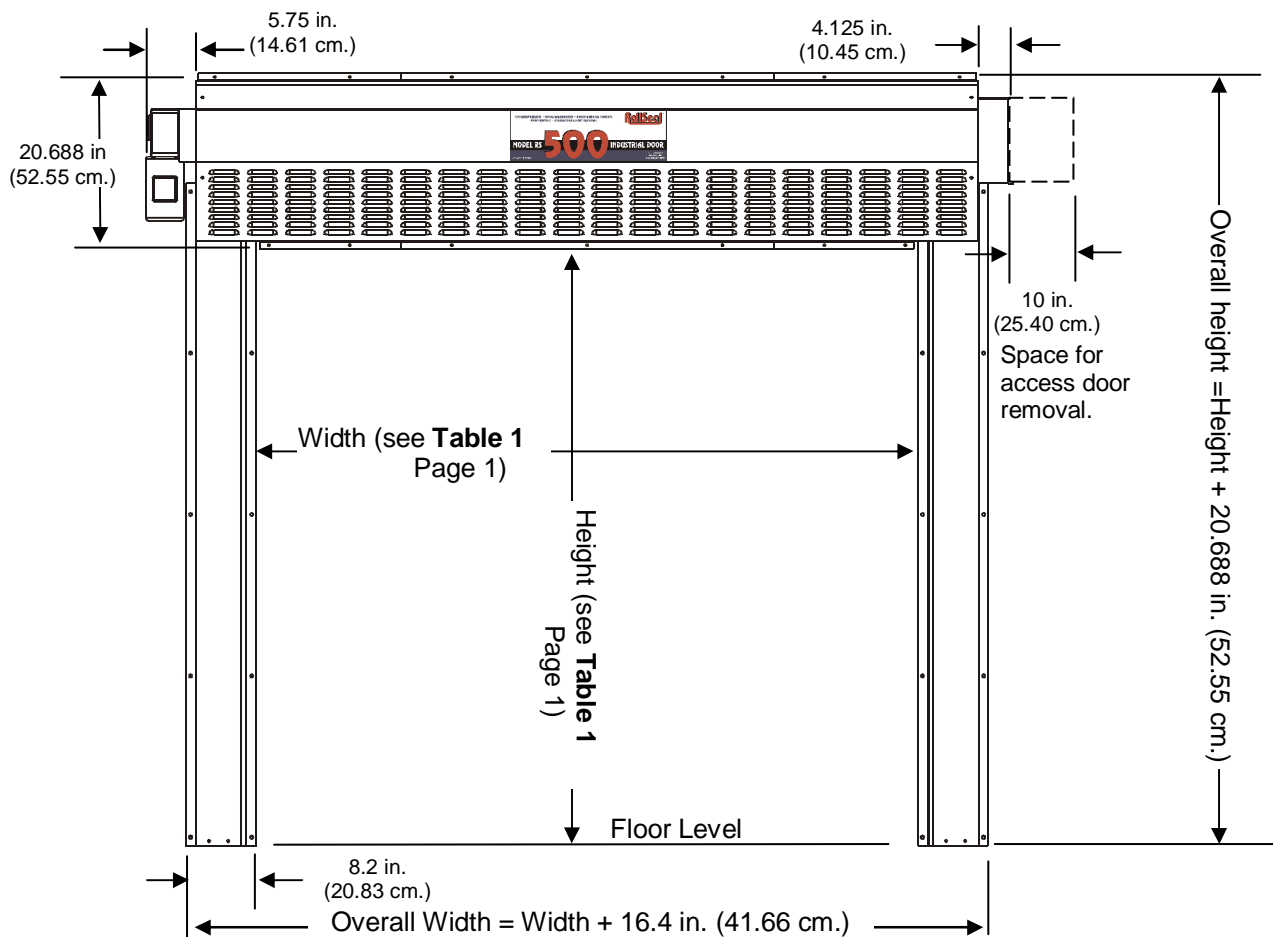

NOTE: Allow 1' (30.4 cm) minimum, preferably 18" (45.7 cm) clearance above the Head Unit for future panel maintenance or replacement.

6.4 Attachment Points of Door

When sizing the clear opening for attachment of the door, pay close attention to the following guidelines. Door flanges have pre-drilled holes that serve as mounting points of door. Flange widths are shown in **Diagram 2**.

1. Make sure that door assembly is plumb & square.
2. The top unit has a top flange and a bottom flange. Make sure these flanges overlap framing.
3. The vertical members have inner flanges and outer flanges. The outer flanges have pre-drilled holes that serve as attachment points. Make sure the outer flanges overlap framing.
4. When door is raised in front of clear opening (**Section 6.7, page 10**), Diagram flanges must be flush against framing for attachment of screws.

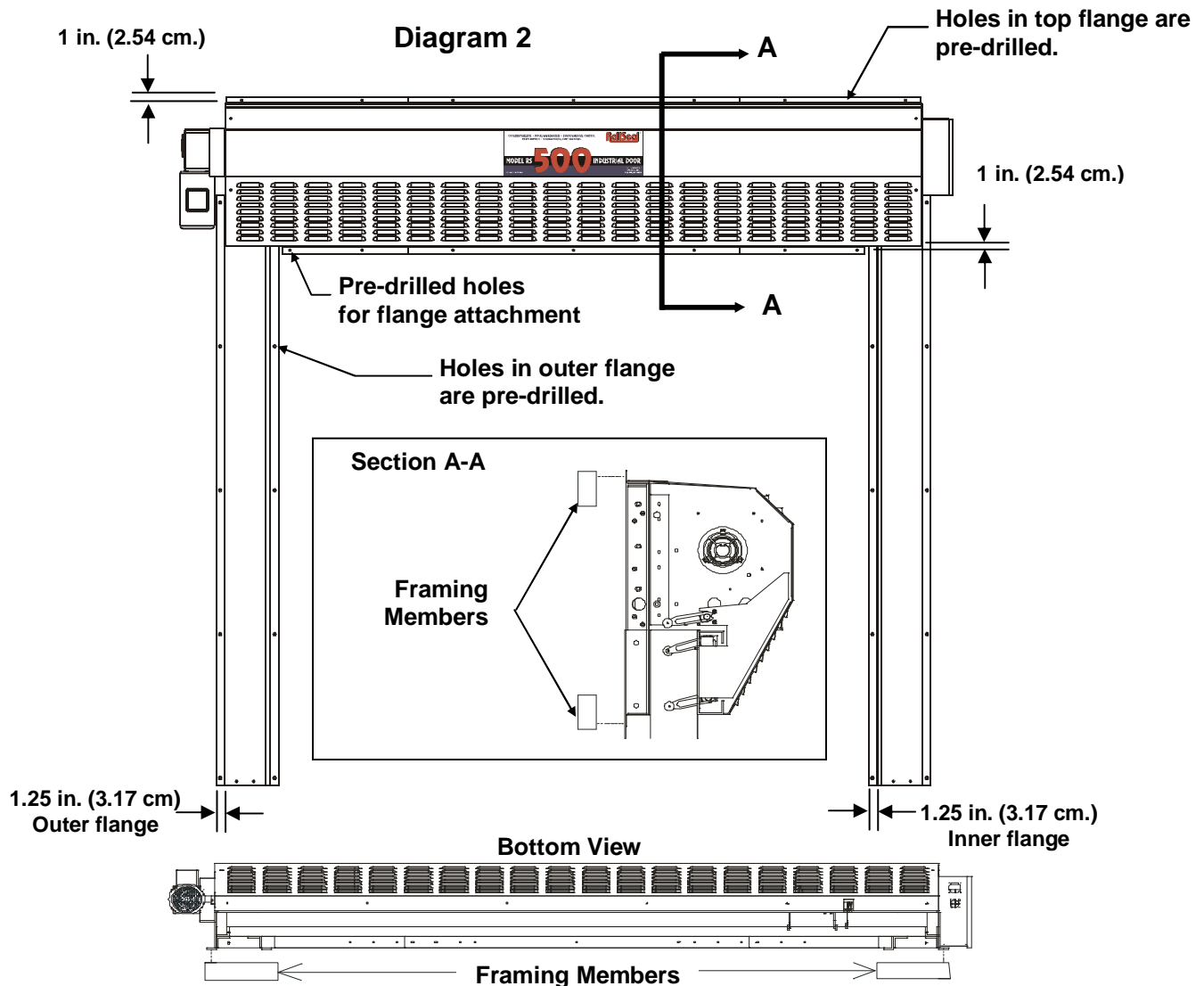

6.5 Assembly of Parts

Arrange the horizontal member, left vertical member (left track), and right vertical member (right track) on the floor in front of the clear opening as shown in **Diagram 3**. The curtain side of the horizontal member and each vertical member faces down.

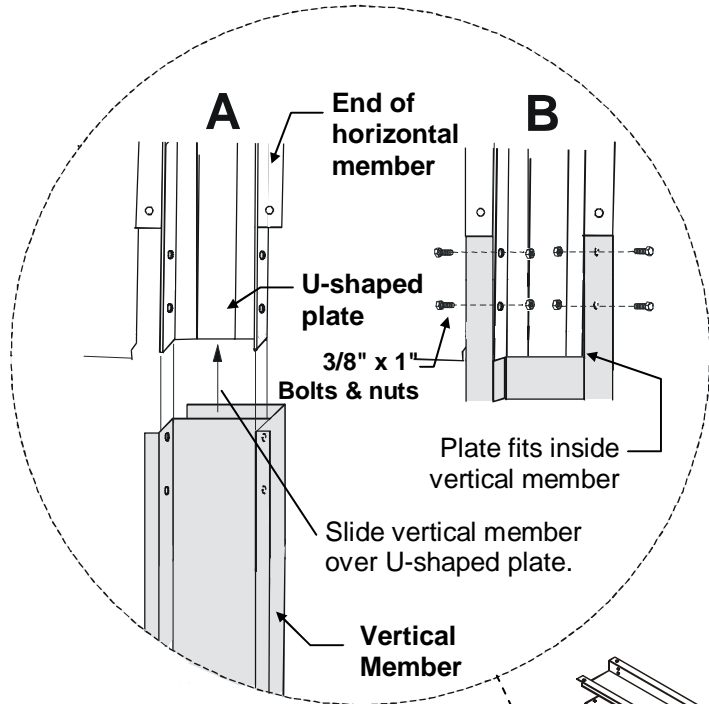

On each end of the horizontal member is a U-shaped plate that fits inside each vertical member. The U-shaped plate has four bolt holes, two on the inside and two on the outside flanges that match bolt holes in the vertical member. See diagram at left.

1. Align the vertical member with the U-shaped metal plate at end of horizontal member.
2. Slide the vertical member onto the outside of the U-shaped metal plate of the horizontal member as shown in A.
3. Insert bolts through bolt holes as shown in B. Install nuts. Tighten bolts & nuts securely.

Clear Opening
At this end of members

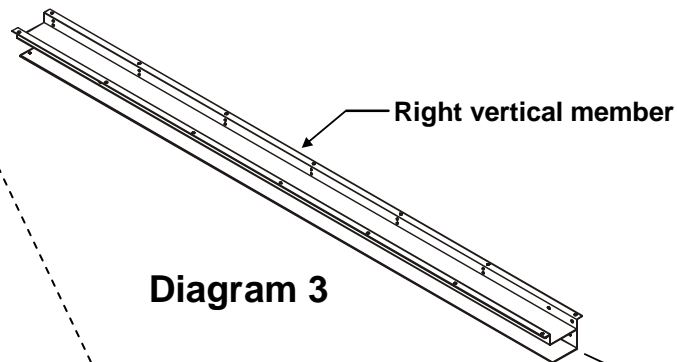

Placement of Parts for Assembly

Lay left track, right track, and horizontal member face down in front of the clear opening as shown.

6.6 Infrared Sensor Connectors

Located at the bottom of each vertical member is an infrared detector. The detector on each vertical member operates as a safety device if the infrared beam is interrupted. Door can be set to stop if beams are broken while closing or to stop and reverse to the full open position. Refer to the RollSeal SC-325 Controller Manual for more information.

1. Locate female connector on vertical member. This connector is attached to the infrared detector.
2. Locate male connector on horizontal member. Unroll cable until connectors meet.
3. Plug connectors together. Make sure connectors interlock.
4. Repeat for both infrared detectors.
5. Cable ties and adhesive mounts are supplied to secure wire to the inside of tracks.

NOTE: For each vertical member, unroll respective sensor cable attached to horizontal member until cable reaches the connector attached to the vertical member. Plug connectors together. Some slack must be left at photo eyes for replacement purposes.

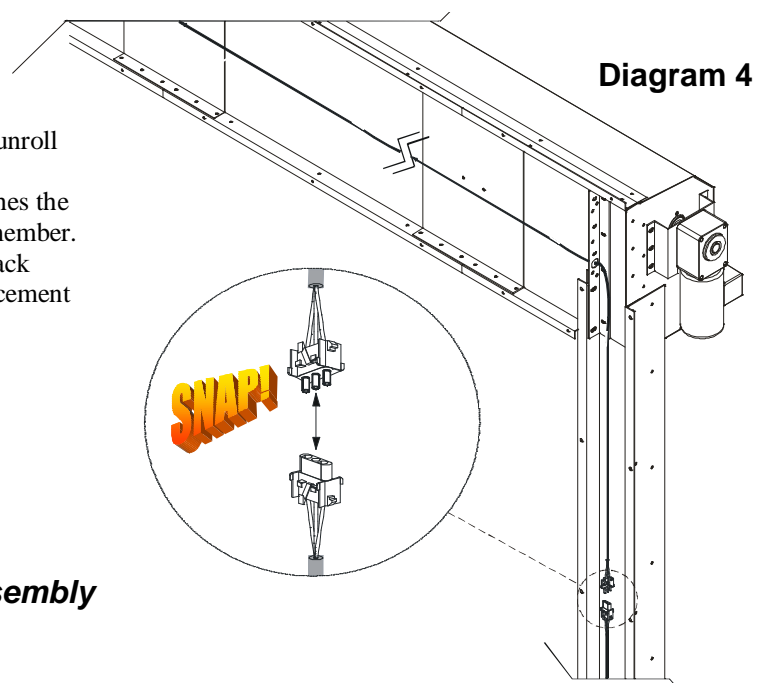

Diagram 4

6.7 Fastening Door Assembly to Clear Opening

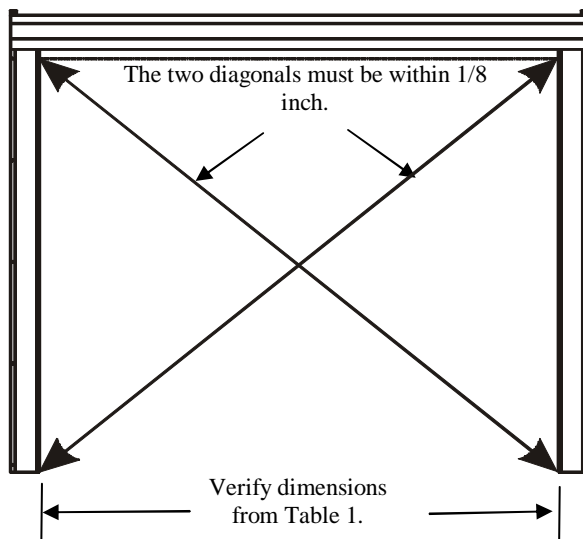

Diagram 5

1. Use a tape measure and make sure that the overall height and overall width of the clear opening meet the requirements: Overall Height = Height + 20.688 in. (52.55 cm), Overall Width = Width + 16.4 in. (41.66 cm). Reference **Table 1** and **Diagram 1**.
2. Make sure that door assembly is plumb & square. See Diagram 5.

- Center door assembly on clear opening. Align the bottom of each vertical member with the respective framing board or posts of the clear opening.
NOTE: The vertical members should be aligned so that their outer flanges will exactly overlap with the framing boards or posts when the door assembly is raised into position.

- Assemble workers and equipment into position on each side of the door assembly.
IMPORTANT: SLOWLY LIFT TOP OF DOOR ASSEMBLY TO RAISE THE DOOR. See Diagram 6.

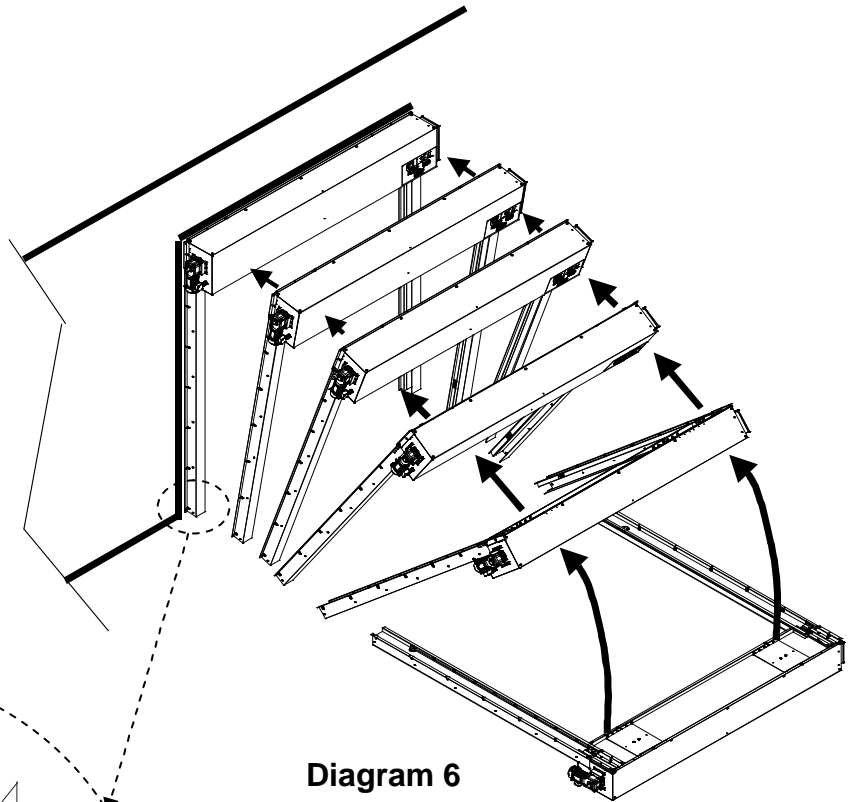

Diagram 6

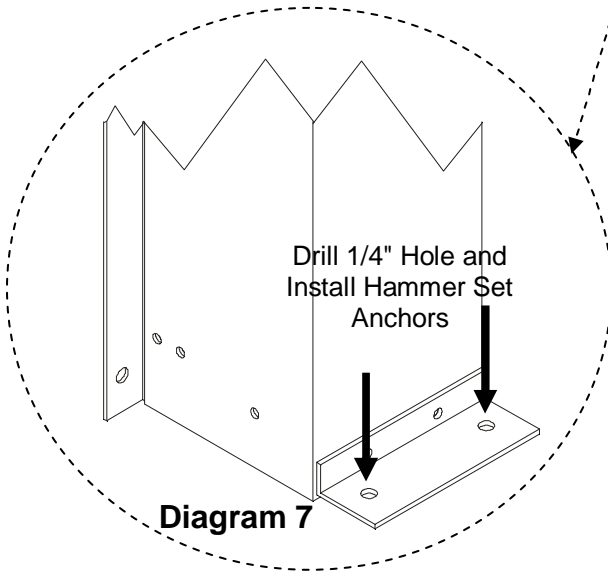

Diagram 7

- Lean door assembly upright against clear opening.
- Carefully press flanges of the door assembly flush against faces of framing boards or posts.
- Fasten Tek screws (in steel) or lag screws (in wood) through the flanges on sides of door assembly. Securely tighten all screws.
- On the lower and upper flanges of the horizontal member there are attachment points for fastening screws. Fasten Tek screws (in steel) or lag screws (in wood) through the holes. This secures the top of the door to the clear opening.
- Locate the two floor mounting holes at the bottom of the left and right tracks. See Diagram 7.
- Drill a 1/4" hole and install Hammer Set Anchors (1002-6030) in both right and left tracks. See Diagram 7.
- This completes fastening of the door assembly to the clear opening.

6.8 Connecting the Electrical Power

- Wire RollSeal SC-325 Controller to Door Control Box.
- Refer to RollSeal SC-325 controller manual for instructions on wiring.

7. Operation of Door

Refer to the RollSeal SC-325 Controller Manual for initial setup. After wiring the controller to the door, connect electrical power to the controller. The door is now ready for operation.

The controller keeps track of the "open" and "closed" positions of the door by means of a mechanical encoder wheel that is located in the

control box. The controller electronically counts steps as the wheel turns to keep track of the door position.

The door seals by means of 'hook & loop' strips along the edges of the door curtain and vertical members.

To Operate Door:

1. Depress manual control button. Door curtain will unroll to 'closed' position.
2. Depress manual control button. Door curtain will roll up to 'open' position.

Depress button to open or close door as desired.

Open and close the door a few times to test door operation and remove any wrinkles in the door curtain.

If you detect any problems, STOP. Disconnect electrical power. Contact your distributor for assistance.

8. Limit Switches

There are three limit switches located within the horizontal member mechanism. See Diagram 8. These switches are attached to levers that contact the curtain. The **home switch** sets the 'open' position of the door curtain. When the curtain is raised, the home switch limits the height to which the curtain opens. The **safety switch** is a fail-safe switch that stops the curtain in the unlikely event of malfunction of the home switch. The **lead-edge switch** is a switch that stops the curtain in the event of a doorway obstruction.

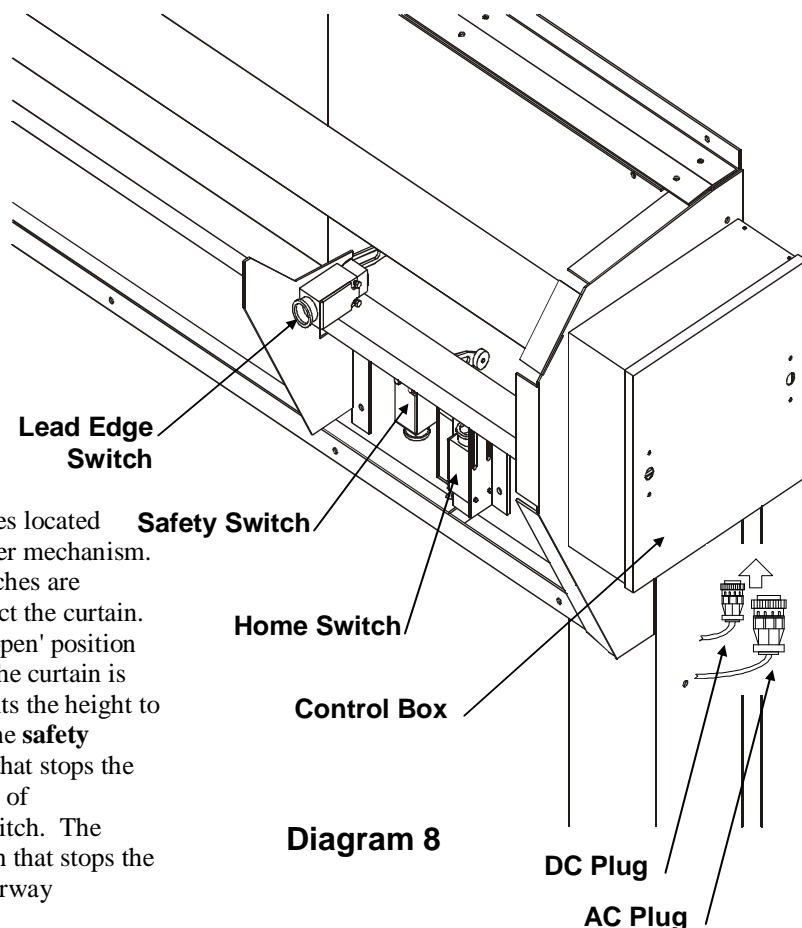

9. Manual Operation of Door

9.1 Operating Instructions

The RS-500 door can be operated manually in the event of a power outage or if there is a motor malfunction. To operate the door manually, perform the following instructions.

Warning!

Disconnect All Electrical Power To Motor Before Attempting To Operate The Door Manually!

Warning!

The Curtain Is Released When Brake Lever Is Disengaged. Do Not Disengage Brake Until Door Opening Is Clear!

If door is OPEN (door curtain raised) perform the following steps:

1. Locate brake lever at bottom of motor. (See diagram below).
2. Carefully release brake by flipping lever down. CAUTION: Curtain will drop when brake is released.

If door is CLOSED (door curtain lowered) perform the following steps:

1. Locate brake lever at bottom of motor.
2. Carefully release brake by flipping lever down.
3. Motor shaft is accessible from bottom of motor. Use provided Crank Handle to rotate motor shaft.
4. Carefully turn motor shaft counterclockwise to raise door curtain. NOTE: The drive (as viewed from the 'motor end' of door) is synchronized with clockwise or counterclockwise rotation of the motor shaft
5. When door curtain has been raised to desired height, flip brake lever up to engage brake.

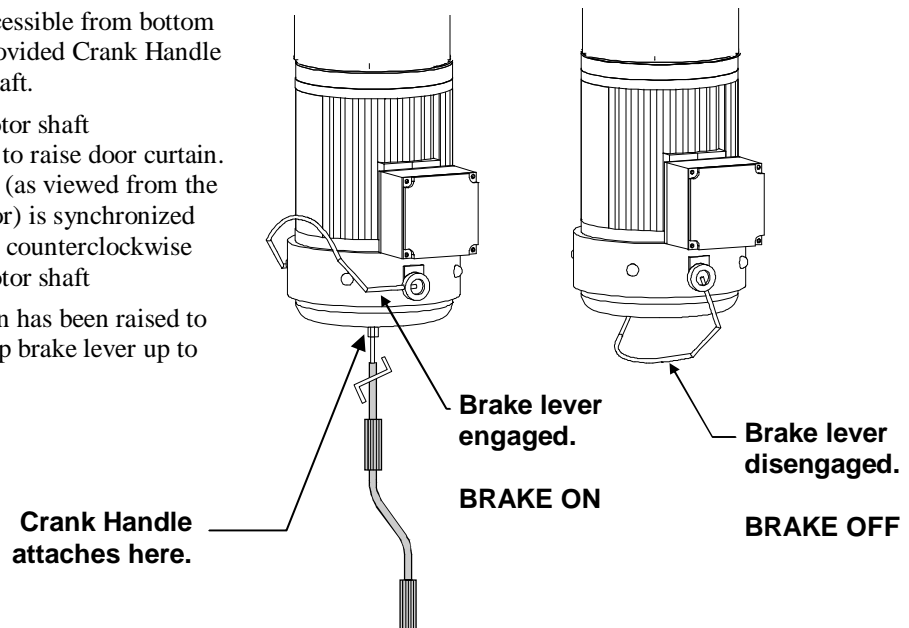

9.2 Adjustment of Brake

After extended operation of the brake lever, the brake may become worn. As the brake wears, some adjustment to the brake is required. Lettered diagrams below correspond to lettered instructions. Follow instructions to adjust brake:

1. Close door curtain to fully lowered position.
2. Engage Brake lever.
3. Disconnect electrical power to motor.
4. Remove four Phillips screws (**A**).
5. Remove cover (**B**).
6. Straighten the bent tab (**C**) of spider nut.
7. Tighten spider nut (**C**) snugly against blower wheel. Make sure a tab of spider nut is aligned with a notch in the shaft.
8. Bend tab (**C**) downward into notch of shaft.
9. Replace cover (**B**).
10. Replace four Phillips screws (**A**).
11. Disengage brake lever (**D**).
12. Adjustment complete.

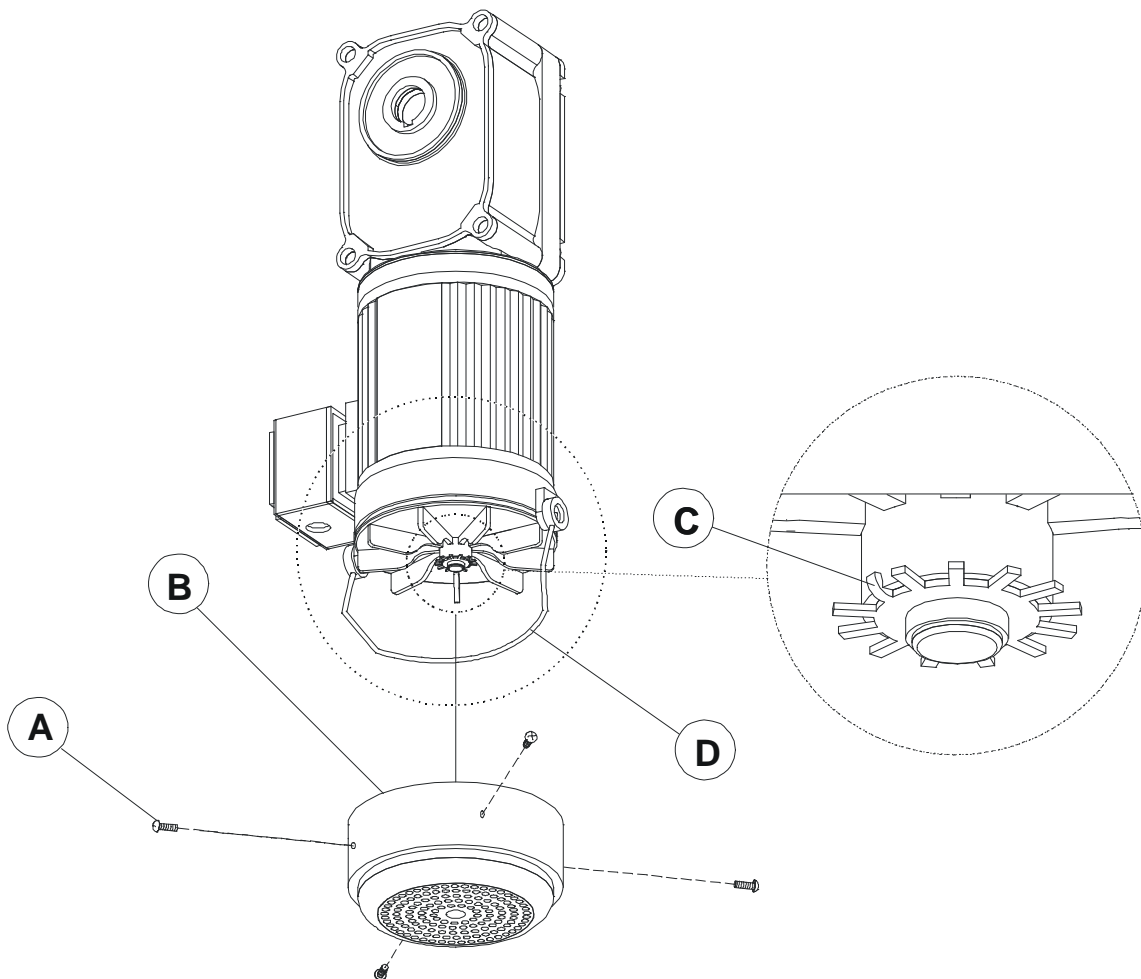

10. Emergency Egress

The Emergency Egress feature provides a simple and convenient means of exiting a Roll Seal RS- 500 Door from the inside of the structure should the door motor become inoperative due to a power failure or other conditions.

INSTALLATION

Install the two Strap Retainers (1040-8400) to the inside of the top door jam and the left door jam as shown below. For a wood framed door jams use two #10x1" screws (1004-1386). For a metal framed door jam use two #8x1/2 Tek screws (1004-2492).

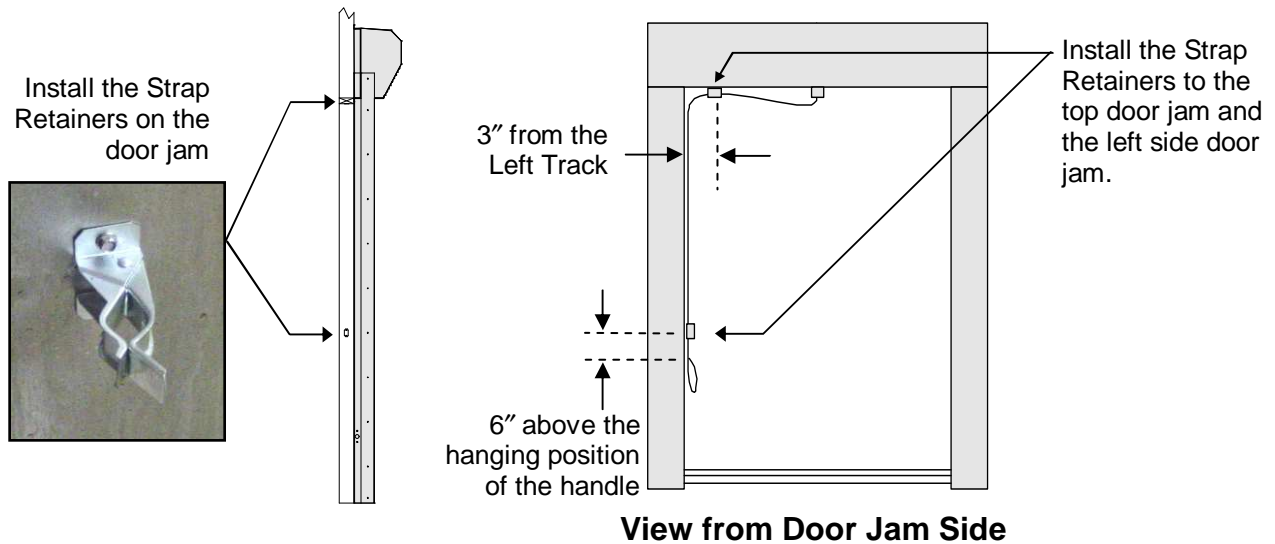

EXITING (OPENING) THE DOOR

When exiting the door, first pull the Emergency Strap from the retainers on the side of the door. See Step 1 below. Next pull down on the strap until the door stops. See Step 2. This will allow the doors to open enough for a person to exit the structure.

Step 1

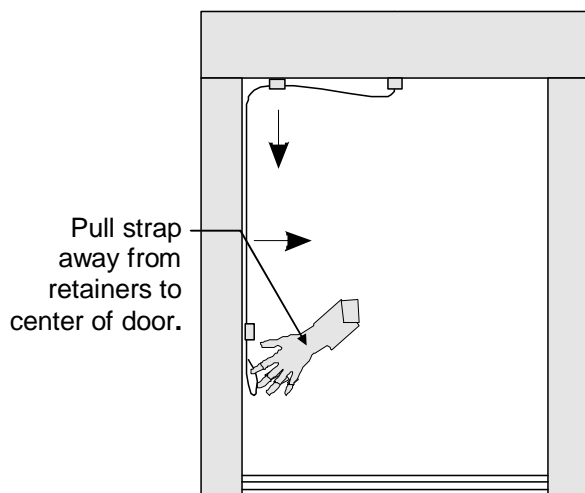

Step 2

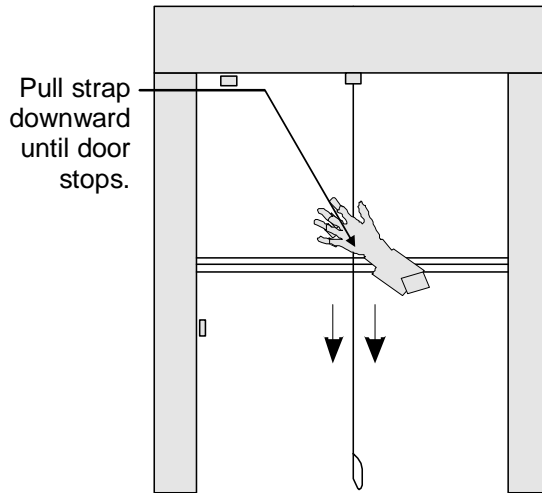

RESETTING (CLOSING) THE DOOR

After the RS-500 door is opened by using the Emergency Egress Strap, the door must be carefully re-set to ensure proper operation in the future. First, firmly hold strap, then press the Cam Buckle Release. See Closing Step 1 below. *Caution: When the Cam Buckle is released, the door will rapidly close unless tension is held on the strap. Keep fingers away from buckle while closing.*

Step 1

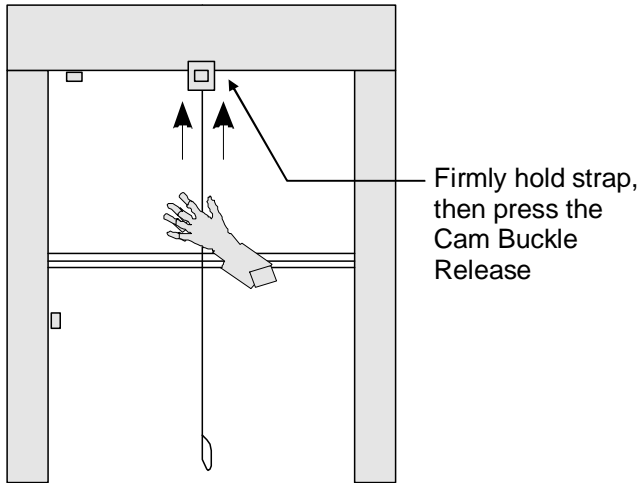

Step 2

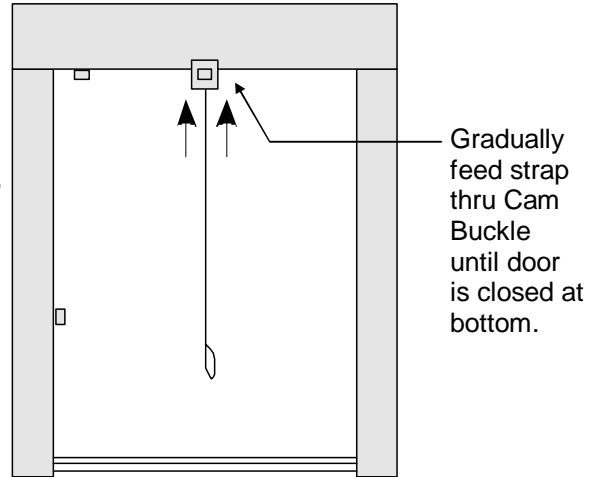

Gradually feed strap through Cam Buckle until the LIMIT mark is at the Cam Buckle base. See Steps 2 and 3. Place strap securely in retainers to prevent the strap from drooping in the center. See Step 4.

Step 3

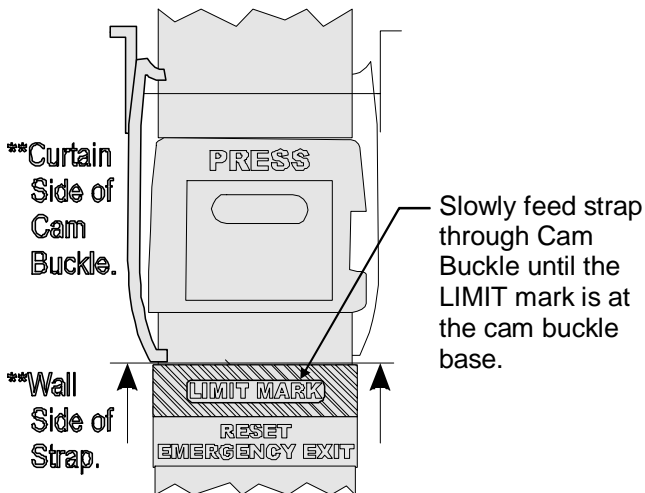

Step 4

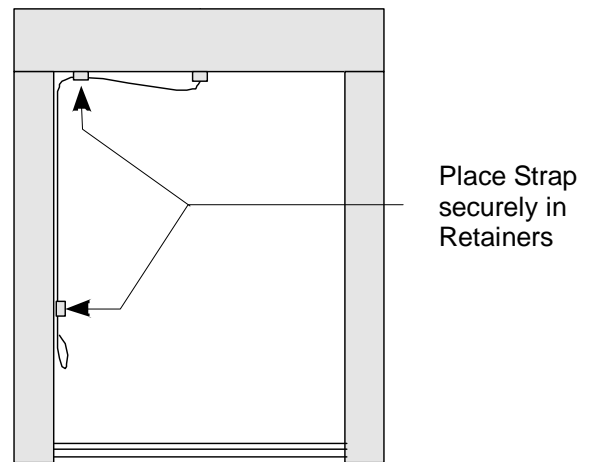

Cycle the door up and down in normal operating mode to ensure proper re-setting of the door. Adjust if necessary. Door should now function normally.

11. Egress Strap Removal/Re-Installation

11.1 REMOVAL

1. Locate the door controller and turn off the power switch on the left side of the controller.
2. Remove the door's head unit cover.
3. Place the door in the JOG mode by holding the Up and Down arrows on the controller at the same time until you see "JOG" in the controller's display.

Warning: Watch the panel closely while you are slowly jogging/rolling the curtain up on the drive shaft. Stop when you see the area where the long egress strap is connected to the short egress piece attached to a triangle panel. This

should bring the strap, connection point, right to the top for easy access. Failure to stop can cause curtain to reverse direction and damage door components.

4. Find the area where 2 loops are attached with a quick-link, unscrew the quick-link that attaches the long yellow strap loop to the yellow loop of the triangle piece. Make sure **not to drop the weight** into the door.
5. Access the inside area of the cooler/freezer box through the door opening. If the strap is hanging inside, unhook and remove the gold buckle and the damaged yellow strap (top center of door) from the door.

11.2 INSTALLATION

1. Locate the door controller and turn off the power switch on the left side of the controller.
2. Remove the door head unit cover if it has not been removed previously.
3. Un-roll the yellow egress strap with attached gold buckle.

NOTE: Insert the strap through the hole in the center of the door, near the top, where original strap was traveling down inside the curtain and to replace the old gold buckle with the new one

4. Proceed to the outside area and locate the roller assembly at the top center of the door where the original strap came into the curtain area from the inside cooler/freezer area. Use anything with some stiffness (banding Material) and feed the stiff item through the roller and down through the slot located in the inside cooler/freezer area and tape or tie it to the small loop (NOT the LARGE

LOOP of the yellow strap. Then gently pull it through the hole and roller assembly at the top/center of the door.

5. Ensure the yellow strap is not twisted. Place the counter weight onto the yellow strap.
6. Attach the new strap (small loop) that you just pulled into the curtain area to the (small loop) strap on the triangle piece of panel using the quick-link.
7. Attach the gold buckle to the door and hang the egress strap in the clips away from the door opening.
8. With the controller still in JOG mode, use the down arrow to lower the door to the floor. Exit JOG mode by holding the Up and Down arrows on the controller at the same time until you see "---" in the display of the controller.
9. Press Open on the 2 button switch. The door should open, timeout, and close. If it does, run it open and close several times. If it works well then go to step 10. If not, notify tech support of the manufacturer.
10. Re-attach the cover

12. Door Panel Adjustments

During normal operation, the tension pipes should run in close proximity of each other. The clearance between the tension pipes should normally be between 1/4" to 1/2" (6.35 mm - 12.7 mm). There are two situations pertaining to the tension pipes that may cause problems with door operation. If the tension pipes are too far apart, the tension pipes will not repel each other. This causes poor contact between the hook & loop. On the other hand, if the tension pipes are riding one another (i.e. touching one another), the door panel material does not flow evenly, thus leaving wrinkles in the panel instead of a stretched, smooth & even appearance.

Adjustment Procedures

The clearance between the tension pipes can be adjusted by raising or lowering the door panels. Each door has three panels: (1) The inside panel (panel facing the inside of building) is attached to the back plate. (2) The center panel is attached to the roller. (3) The outside panel (facing the outside of building) is attached to the front bar. Adjustments are made to the inside panel and/or the outside panel.

To adjust the height of the outside tension pipe, raise or lower the outside door panel by detaching the panel hook & loop from the front bar, and raising or lowering the panel. Then re-attach the panel loop to the hook on the front bar. Be sure to keep the tension pipe level during this procedure.

To adjust the height of the inside tension pipe, raise or lower the inside door panel by detaching the panel hook & loop from the back plate, and raising or lowering panel. Then re-attach the panel loop to the hook on back plate. Be sure to keep tension pipe level during this procedure. Install Tek screws through the panel material and into the back plate to securely hold the material in place.

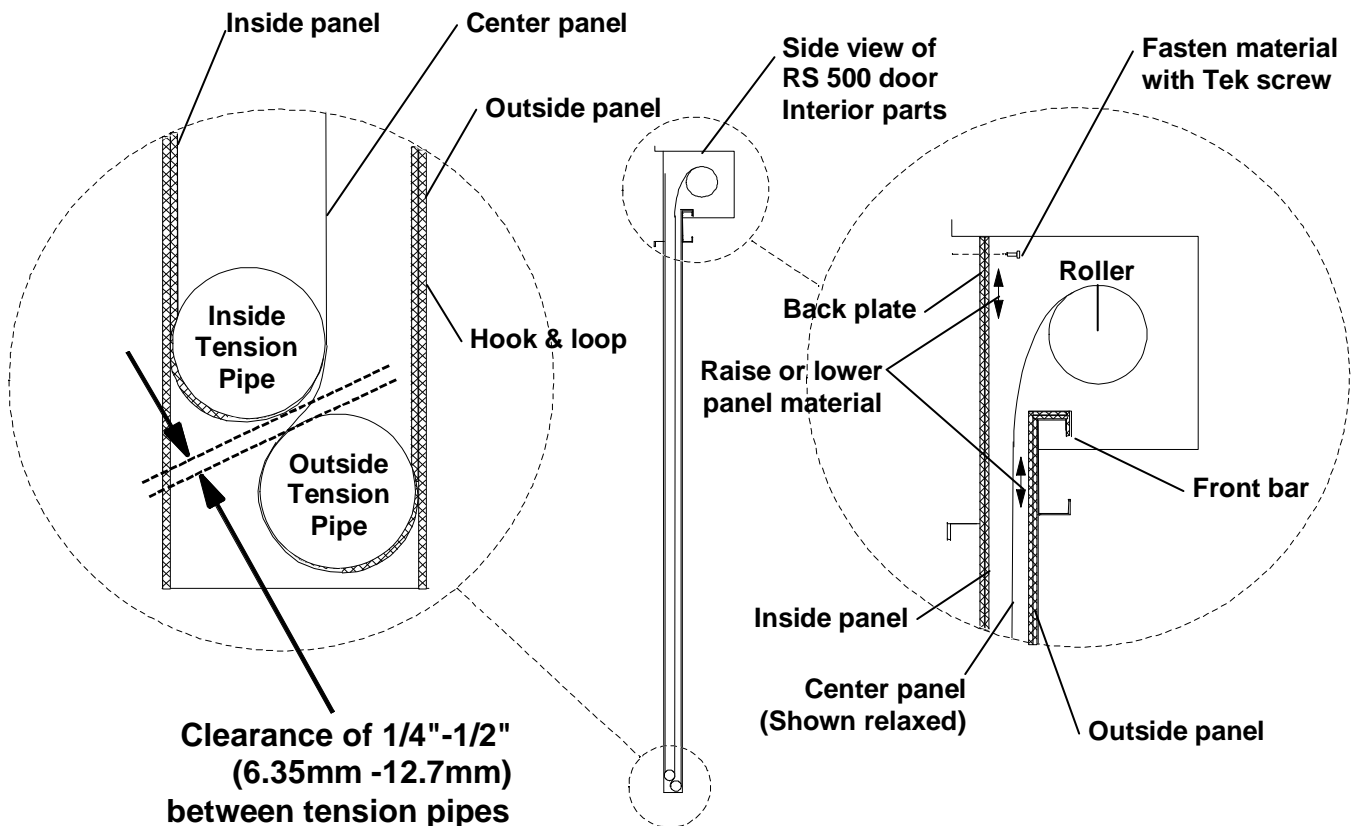

13. Removal of Existing Panel

1. Locate the door controller and turn off the power switch on the left side of the controller.
2. Locate the brake on the motor. It resembles a paint bucket handle that has been pushed upon a clip. Pull the brake release handle down towards the floor. This will allow the panel to go to the floor.

NOTE: You may have to assist by rolling the panel downward.

3. Remove the lowered cover from the door head unit.
4. Locate the 3 fabric sheets that make up the entire door curtain. **See FIGURE 24, DETAIL 2 below.** The center panel has a hook & loop strip across the top. The center panel does not have magnets or hook & loop strips on the sides. The inside & outside panels have hook & loop strips at the top, and magnets or hook and loop strips along the sides of the panels. The outside panel may be identified as the longer of the two panels.
5. Mark the end of each sheet and along the edge of each sheet with a marker. This will prove vital to ensure you install the new panel sheets at the proper locations to alleviate major curtain adjustment.
6. Remove the 3 screws from each sheet (front, center, and back) **see FIGURE 24 DETAIL 2** and detach the hook and loop area of each sheet left to right, starting with front, then center, and then back sheets. Let the panel/curtain fall to the floor.

NOTE: If the door is equipped with an egress assembly you will see the yellow egress strap attached to a triangle piece of material with a quick-link connector. If it does not have this strap, read the notes below and proceed to next step 8.

7. Un-screw the quick-link connector and allow the panel to hit the floor.

NOTE: Observe how the tension pipes are installed before removal. They **MUST** be re-installed first, with one pipe in the front/outer pocket (closest to outside of the cooler) and the other pipe in the back/inside pocket. Locate the back pipe behind the triangle piece that is attached to the yellow strap. The front/outer pipe will always hang lower than the back/inside pipe.

NOTE: Failure to install properly could result in door sticking up.

8. Slide the 2 tension pipes out of their respective pockets. Remove the panel/curtain away from the door. You are now ready to install the new panel/curtain.

14. Installation of Replacement Panel

1. Place the new panel in front of the door opening and make sure the part number label is on the left side.

NOTE: If door is equipped with egress system yellow strap ensure that the strap is positioned to the front side of the back/inside panel to allow connection to the triangle piece of material with the quick-link connector.

2. Take the back/inside curtain (**Detail 1 and Detail 2**) and attach the material to the backplate placing material on the marks that were created during removal of old panel.
3. After the inside curtain has been attached, attach the egress strap (if equipped) to the triangle piece of material with the quick link connector.
4. Take the outside curtain (**Detail 1 & Detail 2**) and attach to the top bar.

NOTE: Ensure all roller switches (home, safety and leading edge) are pointing down.

5. After the curtain has been secured, install the bottom pipes in the curtain as shown in **Detail 3**. The front pipe should be installed first. Then the back pipe is placed in front of inside panel but behind the yellow strap and triangle piece of material. It should be above the front pipe.
7. Ensure all panels are inside the tracks on both sides. Set the controller to JOG mode by holding both arrows at the same time until you see "JOG" on the display. JOG up and down, using up and down arrows to straighten the panel. Exit JOG mode by holding both arrows at the same time. Run the door as normal.

Fig. 24
Curtain Installation

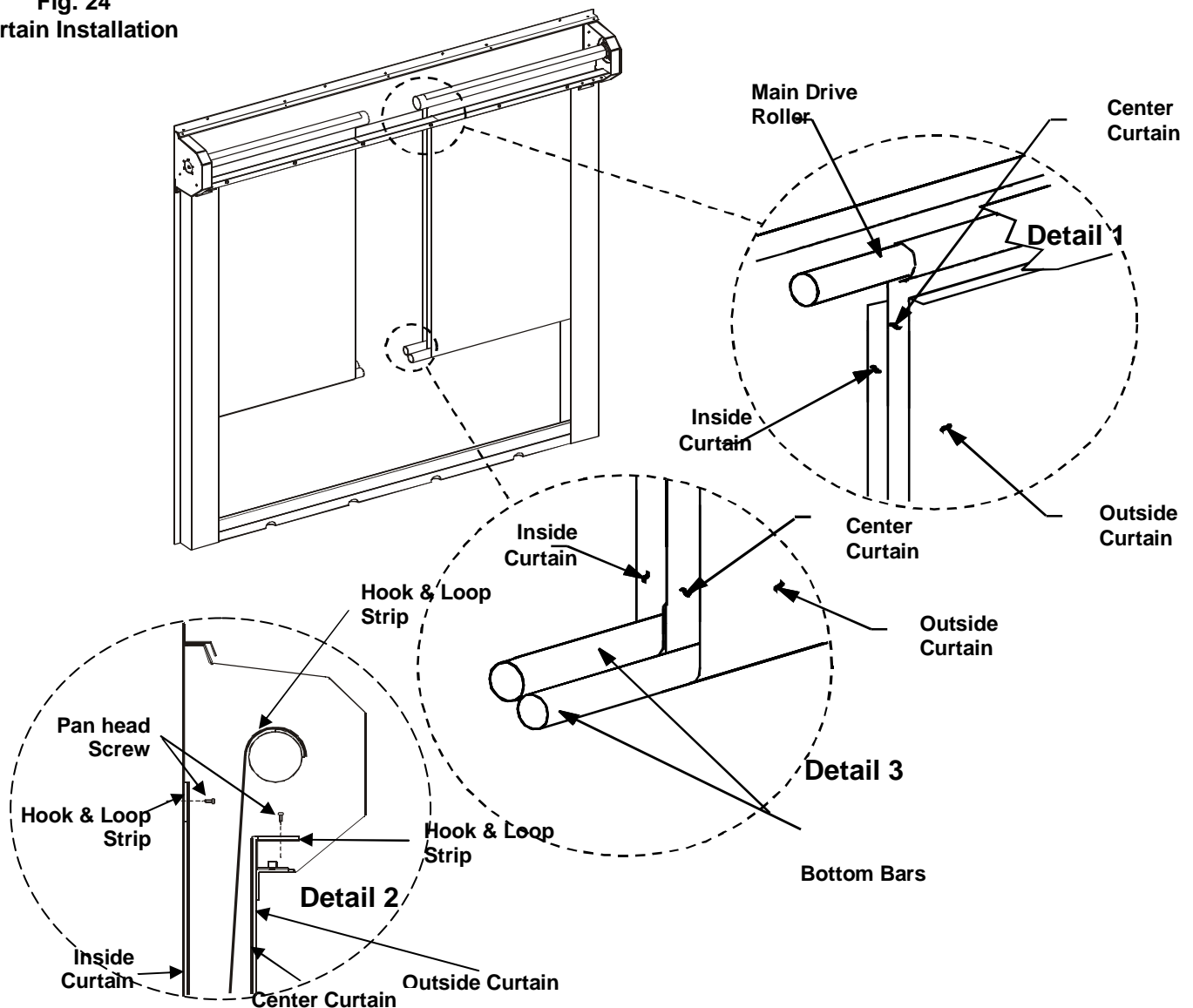

15. RS-500 Door Wiring Diagram

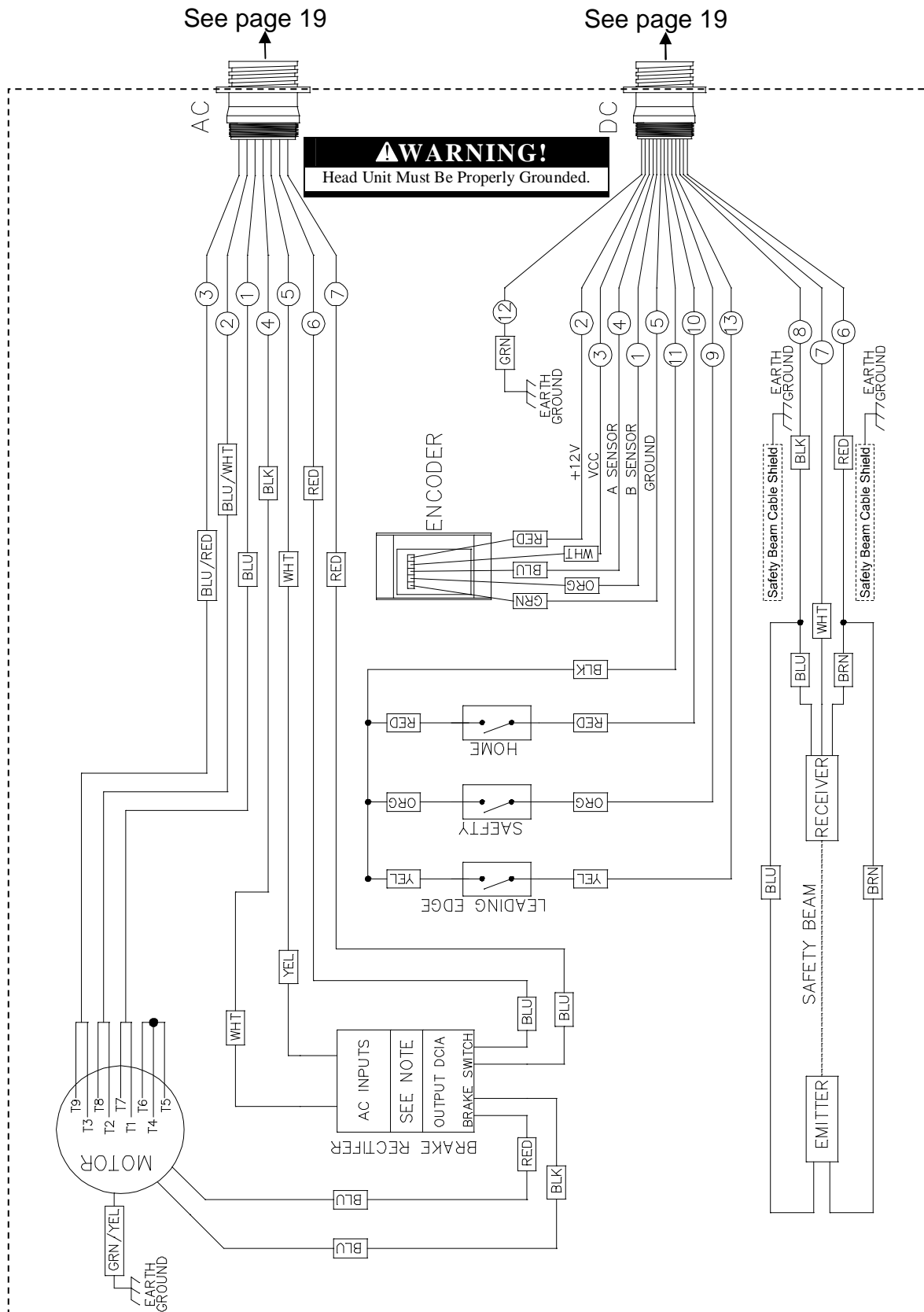

16. RollSeal Smart Controller Wiring Diagram

